



USER MANUAL

# PDM DUO

V1.2 03.10.24

we watch gas where you can't

# CONTENTS

<b>WARNING</b>	<b>3</b>
<b>CAUTION</b>	<b>4</b>
<b>SPECIAL CONDITIONS FOR SAFE USE</b>	<b>4</b>
<b>1. PRODUCT OVERVIEW</b>	<b>5</b>
1.1. Product Introduction	5
1.2. Product Features	5
1.3. Product Specifications	5
1.4. Gas Types	6
<b>2. COMPONENTS</b>	<b>7</b>
2.1. External Components	7
2.2. LCD Display Symbols	7
2.3. Interface	8
2.3.1. Visual Display	8
2.3.2. Display Icons	8
2.3.3. One-Button Operation	8
<b>3. BASIC OPERATION</b>	<b>8</b>
3.1. System Activation	8
3.2. System Shutdown	9
3.3. Configuration Mode	9
3.4. Calibration	10
3.5. Standard gas concentration for Calibration	11
3.6. Zero Calibration	11
3.7. Span Calibration	12
3.8. Judgement for Implementing	13
3.9. Peak (Max) Value	13
3.10. Alarm Display	13
3.11. Acquiring Alarm Events	13
3.12. Log	14
<b>4. ALARM / TEST FAILURE</b>	<b>14</b>
4.1. Alarm Function	14
4.2. Alarm Setting Values	14
4.3. Alarm Sound, Vibration, LED, and Display (Per Second)	15
<b>5. CERTIFICATION</b>	<b>15</b>
5.1. Explosion-Proof Certification	15
5.2. Manufacturing Approval	15
<b>6. PROTECTION RATING</b>	<b>16</b>
<b>7. WARRANTY AND REPAIR</b>	<b>16</b>
7.1. Sensor Replacement	16
7.2. Warranty	16
<b>8. CONTACT INFORMATION</b>	<b>17</b>

# SAFETY WARNING

Before using the device, ensure that you fully understand this manual. The device must be used and repaired according to the instructions provided. Failure to follow these instructions may result in device malfunction, injury, or even life-threatening situations.

## WARNING

- Do not replace or modify components. Doing so may void the warranty and compromise safety, even if the device is under warranty.
- Do not open or replace the battery in explosive environments. The battery should only be replaced in a safe location.
- Ensure that there is no foreign matter on the surface of the sensors, LEDs, or buzzer before use.
- Regularly test the gas sensor's performance using gases that exceed the alarm levels.
- Regularly test the LED, alarm, and vibration functions to ensure they are functioning properly.
- Use the device within the specified temperature, humidity, and pressure ranges. Using the device outside of these conditions may lead to malfunction or failure.
- The sensor inside the device may display different gas concentrations depending on environmental factors such as temperature, pressure, and humidity. Always calibrate the detector in environments that are similar to or match the specifications.
- Rapid changes in temperature may cause rapid changes in gas concentration. (For example, when using the detector in areas with significant temperature differences between indoors and outdoors.) Use the device once the concentration has stabilized.
- Severe pressure or impact may cause rapid changes in gas concentration. Therefore, use the device when the concentration is stable. Severe pressure or impact may also cause the sensor or device to malfunction.
- Alarms are set according to international standards and should be adjusted by authorized professionals.
- Battery replacement should be carried out in a safe area where there is no risk of explosion or fire. Using improper replacement parts not approved by the manufacturer may void the warranty.
- IR communication should be carried out in a safe area where there is no risk of explosion or fire.
- Do not expose the detector to poisons such as alcohol or citrus-based products. Poisons can compromise the accuracy and response time of the device.
- If sensor contamination is suspected, confirm using calibration, bump tests, etc.
- This detector is designed to be used in explosive atmospheres where oxygen levels do not exceed 20.9% (v/v). Some sensor outputs may be suppressed in oxygen-deficient environments (<10% v/v).
- Do not charge primary cell batteries. Replace the battery at a WatchGas authorized service center before it is fully discharged.
- Do not calibrate the device when it has been exposed to conditions representing the IP rating.
- Use dedicated calibration caps or calibration equipment for calibration.
- Do not perform calibration during the device's stabilization process after power-up.
- Sudden changes in atmospheric pressure may temporarily destabilize oxygen concentrations.

- Check for obstructions, debris, or blockages in the gas inlet every day before use. If the gas inlet is blocked by contaminants, the actual detected concentration may be measured lower than the normal level.
- The device should be carried at all times and not left unattended.
- If there is a mechanism that generates charges, the exposed metal parts of the enclosure may store electrostatic charges at levels that could be ignitable for IIC gases. Therefore, users/installers should take the aforementioned precautions to prevent static accumulation. This is particularly important when bringing the equipment into Zone 0 locations.

The battery and sensor should be replaced by a WatchGas authorized service center in a safe area where there are no hazardous gases.

## CAUTION

- Please read the manual carefully before use.
- This device is a gas detector, not a measurement instrument.
- If continuous calibration failures occur, discontinue use and contact the manufacturer.
- Test the device every 30 days in a clean air environment free of gases.
- Clean the exterior of the product with a soft cloth; do not use chemical solvents.

## SPECIAL CONDITIONS FOR SAFE USE

- Do not open or replace the battery in explosive environments. The battery should only be replaced in a safe location.
- Only use SB-AA02(P) (Vitzrocell) batteries.
- Do not use the device in environments with temperatures, humidity, or pressure outside the specified ranges.
- Ensure that there are no foreign substances on the sensor, LED, or buzzer before use.
- For consistent performance, periodically test the device with gases that exceed the alarm thresholds.
- If it is found that the film does not comply with inspection conditions, it must be reapplied according to the manufacturer's instructions. Ensure it is not exposed to excessive heat, harsh chemicals or solvents, sharp edges, or abrasive surfaces.

# 1. PRODUCT OVERVIEW

## 1.1. PRODUCT INTRODUCTION

The PDM DUO is a portable diffusion-type gas detector that alerts users to hazardous environments related to gases. The detector displays the concentration of oxygen, explosive, or toxic gases on an LCD monitor. It is easy and simple to operate, and alerts the operator of danger through an alarm, LED, and vibration if the gas concentration exceeds the safe limit. This device displays real-time gas concentrations and identifies maximum and minimum levels. Settings can be adjusted wirelessly or via the WatchGas IR-LINK (optional).

## 1.2. PRODUCT FEATURES

- Equipped with a miniaturized electrochemical gas sensor
- Wireless communication functionality
- Excellent waterproof and dustproof construction
- Replaceable battery design
- Power On/Off capability

## 1.3. PRODUCT SPECIFICATIONS

<b>Model Name</b>	PDM DUO
<b>Sensor Type</b>	Electrochemical, Non-Dispersive Infrared (NDIR)
<b>Measurement Type</b>	Diffusion Type
<b>Case</b>	TPU + Polycarbonate (PC)
<b>Size</b>	56(W) x 89(H) x 21(D)mm
<b>Weight</b>	200g
<b>Operating Temperature</b>	-20°C ~ +50°C
<b>Operating Humidity</b>	15% ~ 90% RH(Non-condensing)
<b>Environmental Conditions</b>	Pollution Degree: "2", Atmospheric Pressure: 80 ~ 120KPa
<b>Operation</b>	A clip is attached to the device, allowing it to be easily carried by the user on a pocket, belt, helmet, etc.
<b>Alarm</b>	Visual (LED), Tactile (Vibration), Audible (95dB) alarms
<b>Display</b>	Liquid Crystal Display (LCD)
<b>Battery</b>	Lithium Primary Battery (Li/SOCl <sub>2</sub> ), Nominal Voltage: 3.6V, Nominal Capacity: 1,200mAh
<b>Rating</b>	Powered by 3.6VDC battery

<b>Battery Life</b>	PDM DUO-1 to 2: Approximately 0.5 years (8 hours of daily use, wireless off) PDM DUO-3 to 9, PDM DUO-A to F: Approximately 2 years (8 hours of daily use, wireless off) ※ Battery life may vary depending on usage conditions and environment.
<b>Calibration Interval</b>	The detector can be calibrated in an appropriate environment as needed.
<b>Accessories</b>	Calibration cap

## 1.4. GAS TYPES

The detector can monitor various types of gases, including oxygen, explosive gases, and toxic gases. It is available in configurations that detect oxygen and explosive gases, oxygen and toxic gases, or toxic and toxic gases.

Model Name		Gas Type	
Model	X	Ch-A	Ch-B
PDM DUO	1	O2	CH4(*)
	2		CO2(*)
	3	O2	CO
	4		H2S
	5		SO2
	6		H2
	7		NO2
	8		NH3
	9		O3
	A	NO2	CO
	B		H2S
	C		SO2
	D	SO2	H2S
	E		CO
	F		CO

※ CH4 and CO2 use NDIR sensors; others use electrochemical sensors.









## 2. COMPONENTS

### 2.1. EXTERNAL COMPONENTS

The PDM DUO is a portable diffusion-type gas detector that alerts users to hazardous environments related to gases. The detector displays the concentration of oxygen, explosive, or toxic gases on an LCD monitor. It is easy and simple to operate, and alerts the operator of danger through an alarm, LED, and vibration if the gas concentration exceeds the safe limit. This device displays real-time gas concentrations and identifies maximum and minimum levels. Settings can be adjusted wirelessly or via the WatchGas IR-LINK (optional).



### 2.2. LCD DISPLAY SYMBOLS

<b>LO</b>	<ul style="list-style-type: none"> <li>Low Alarm</li> <li>1ST Warning</li> </ul>		<ul style="list-style-type: none"> <li>Battery or Calibration Date Check</li> <li>Countdown</li> </ul>
<b>HI</b>	<ul style="list-style-type: none"> <li>High Alarm</li> <li>2nd Warning</li> </ul>		<ul style="list-style-type: none"> <li>Calibration Success</li> <li>Software Version Check</li> <li>Device Settings</li> </ul>
	Alarm Level Exceeded Indicator		Zero Calibration (Fresh Air Calibration)
<b>STEL</b>	STEL Alarm		Span Calibration (Standard Gas Concentration Calibration)
<b>TWA</b>	TWA Alarm		Sufficient Battery Remaining
	Wireless Indicator		Low Battery

## 2.3. INTERFACE

### 2.3.1. Visual Display

The detector features an LCD (Liquid Crystal Display) that shows the following:

- Gas type monitoring
- Alarm levels triggered: low or high (including ppm or %vol concentration levels)
- Alarm settings: low and high

Peak (maximum) alarm exposure

### 2.3.2. Display Icons

The LCD of the detector also includes icons that clearly indicate:

- Alarm type and alarm level
- Diagnostic warnings

### 2.3.3. One-Button Operation

- Activate the detector
- Display alarm set points
- Display maximum gas exposure
- Display remaining days for bump test
- Display remaining days for calibration
- Display firmware version
- Display calibration gas concentration
- Display all LCD icons
- Set up the detector
- Deactivate the detector

## 3. BASIC OPERATION

### 3.1. SYSTEM ACTIVATION

The detector features a single user interface button for implementing functions such as device activation.

1. Before use, check the activation deadline, and do not activate the product if the deadline has passed.
2. Move to a safe environment.
3. Press and hold the button until the 3-second countdown is displayed.
4. The device will then power on, turning on all LCD segments with a short vibration.
5. The detector will operate in measurement mode.



### Process of system On and Boot

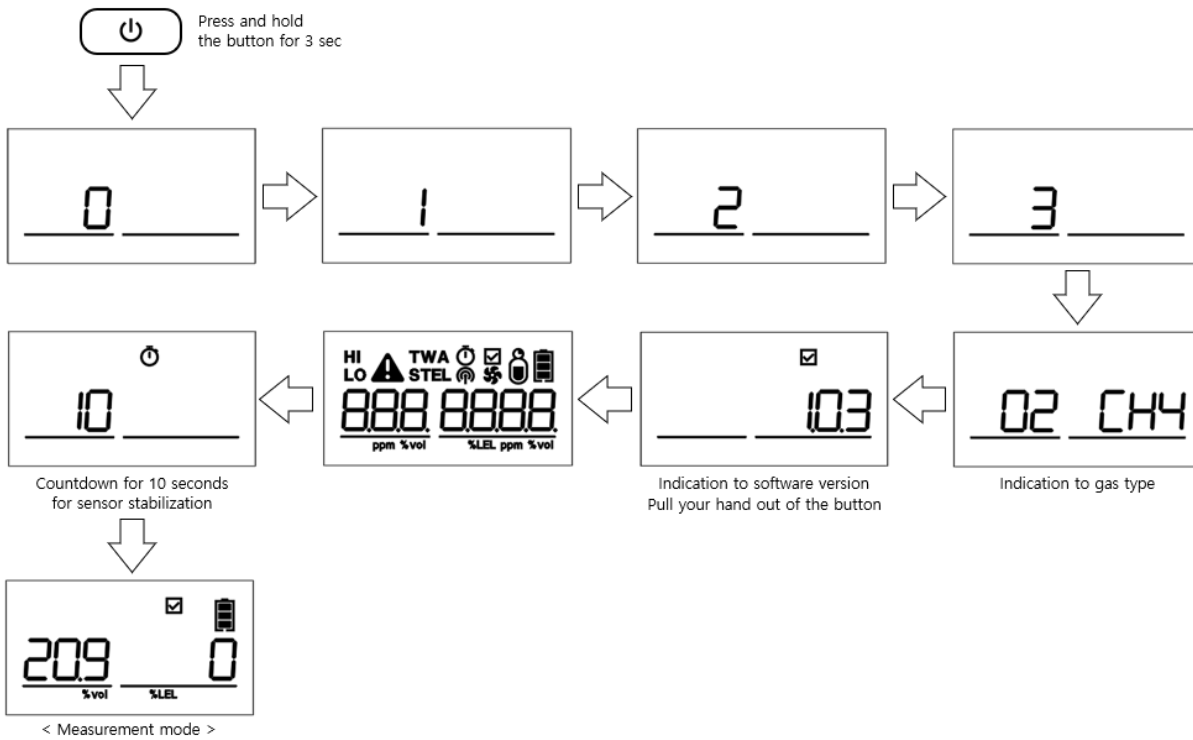

## 3.2. SYSTEM SHUTDOWN

In measurement mode, pressing and holding the button for 3 seconds will display a system shutdown countdown on the LCD.

### Process of system Off

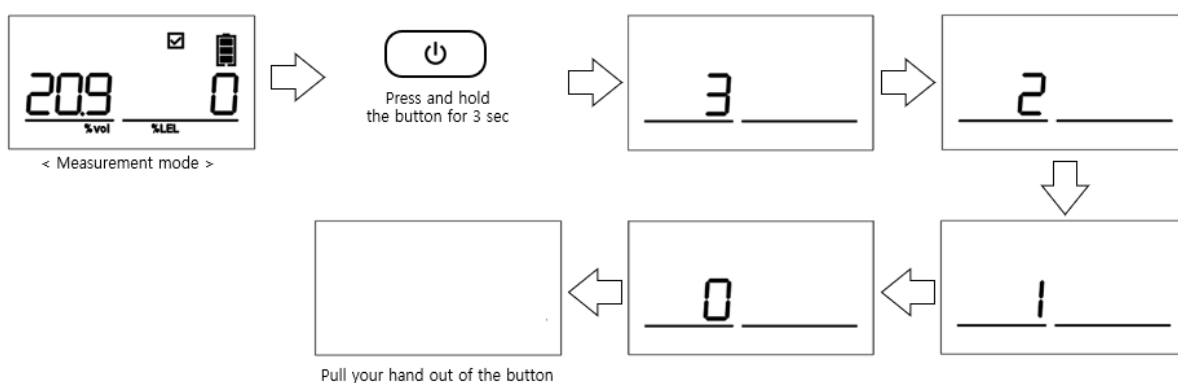

## 3.3. CONFIGURATION MODE

In measurement mode, press the button briefly to switch modes. The device features several modes, as shown in the illustration below. Each mode is distinguished by the active icon displayed on the top screen.

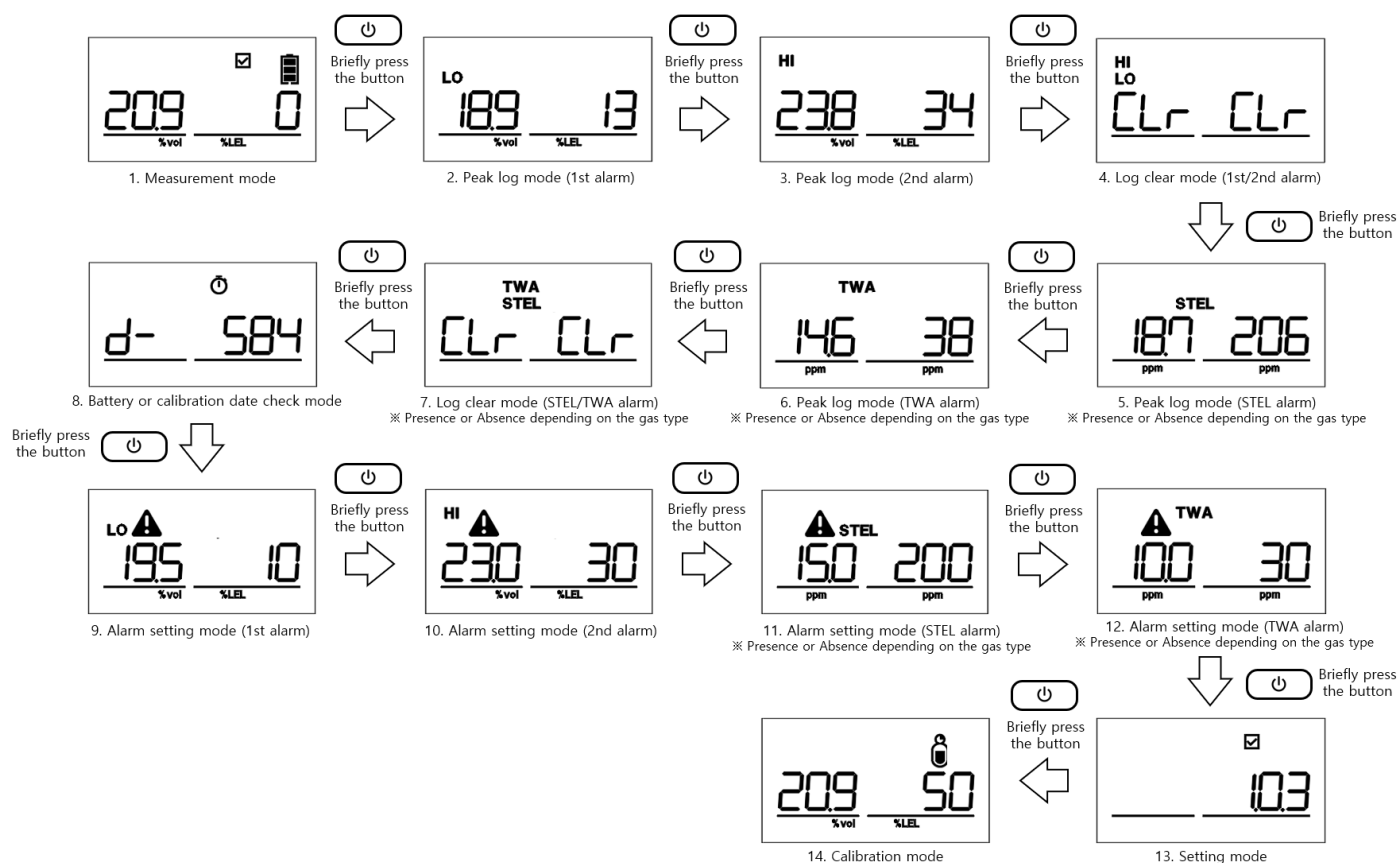

### 3.4. CALIBRATION

For calibration on the device, move the clean atmosphere. And then, perform the zero calibration and span calibration. Ensure to use the exclusive calibration cap or device for calibration. Note that calibration cap must be equipped toward upward arrow pointing.

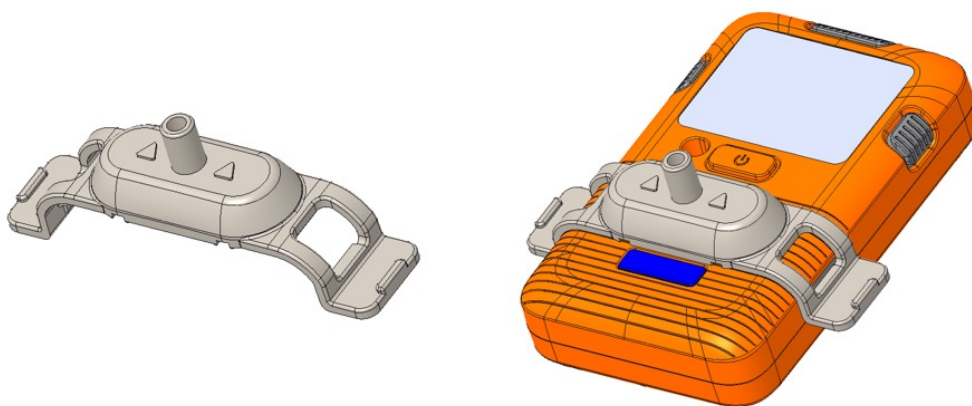

Calibration Cap for PDM DUO series

### 3.5. STANDARD GAS CONCENTRATION FOR CALIBRATION

Be use the standard gas and concentration for each sensor when it's calibrating. Standard gas concentration can be changed using IR-LINK program.

No.	Gas	Sensor type	Measurement Info.		Cal. Standard Concentration
			Range	Resolution	
1	Methane	NDIR	0 to 100 %LEL	1 %LEL	50 %LEL
2	Carbon dioxide	NDIR	0 to 5 %vol	0.01 %vol	2 %vol
3	Oxygen	Electrochemical	0 to 30 %vol	0.1 %vol	18 %vol
4	Carbon monoxide	Electrochemical	0 to 500 ppm	1 ppm	100 ppm
5	Hydrogen sulfide	Electrochemical	0 to 100 ppm	0.1 ppm	25 ppm
6	Sulfur dioxide	Electrochemical	0 to 20 ppm	0.1 ppm	5 ppm
7	Nitrogen dioxide	Electrochemical	0 to 20 ppm	0.1 ppm	10 ppm

### 3.6. ZERO CALIBRATION

Zero calibration means fresh air correction. On the Calibration mode, Press and hold the button for 2 seconds to enter the sub menu. Press and hold the button when the zero-calibration icon is on the display. Select the channel which is implemented zero calibration. And then, Press and hold the button for 2 seconds to calibrating.

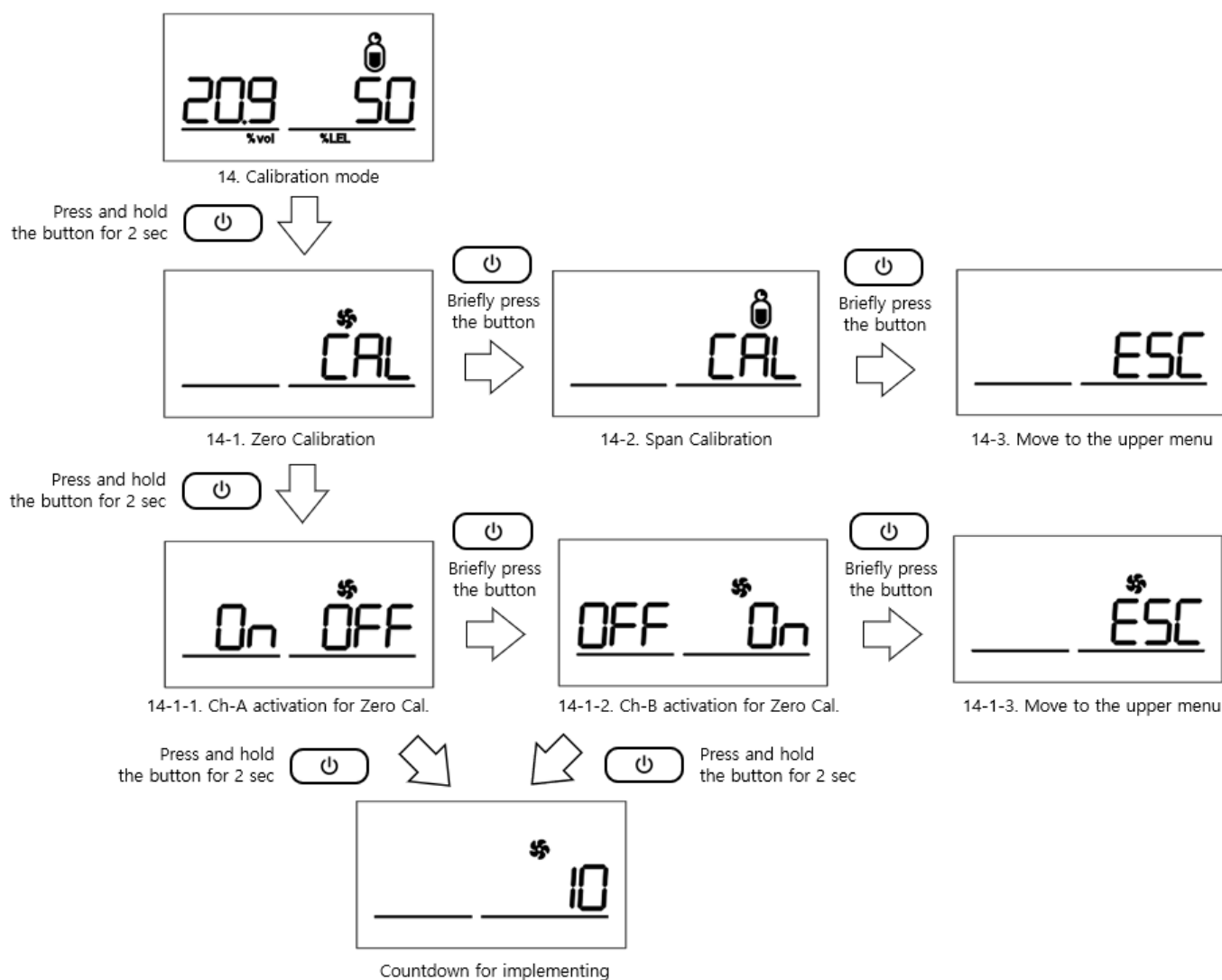

### 3.7. SPAN CALIBRATION

Span calibration means standard gas concentration correction. On the Calibration mode, Press and hold the button for 2 seconds to enter the sub menu. Press and hold the button when the span-calibration icon is on the display. Select the channel which is implemented span calibration. And then, Press and hold the button for 2 seconds to calibrating.

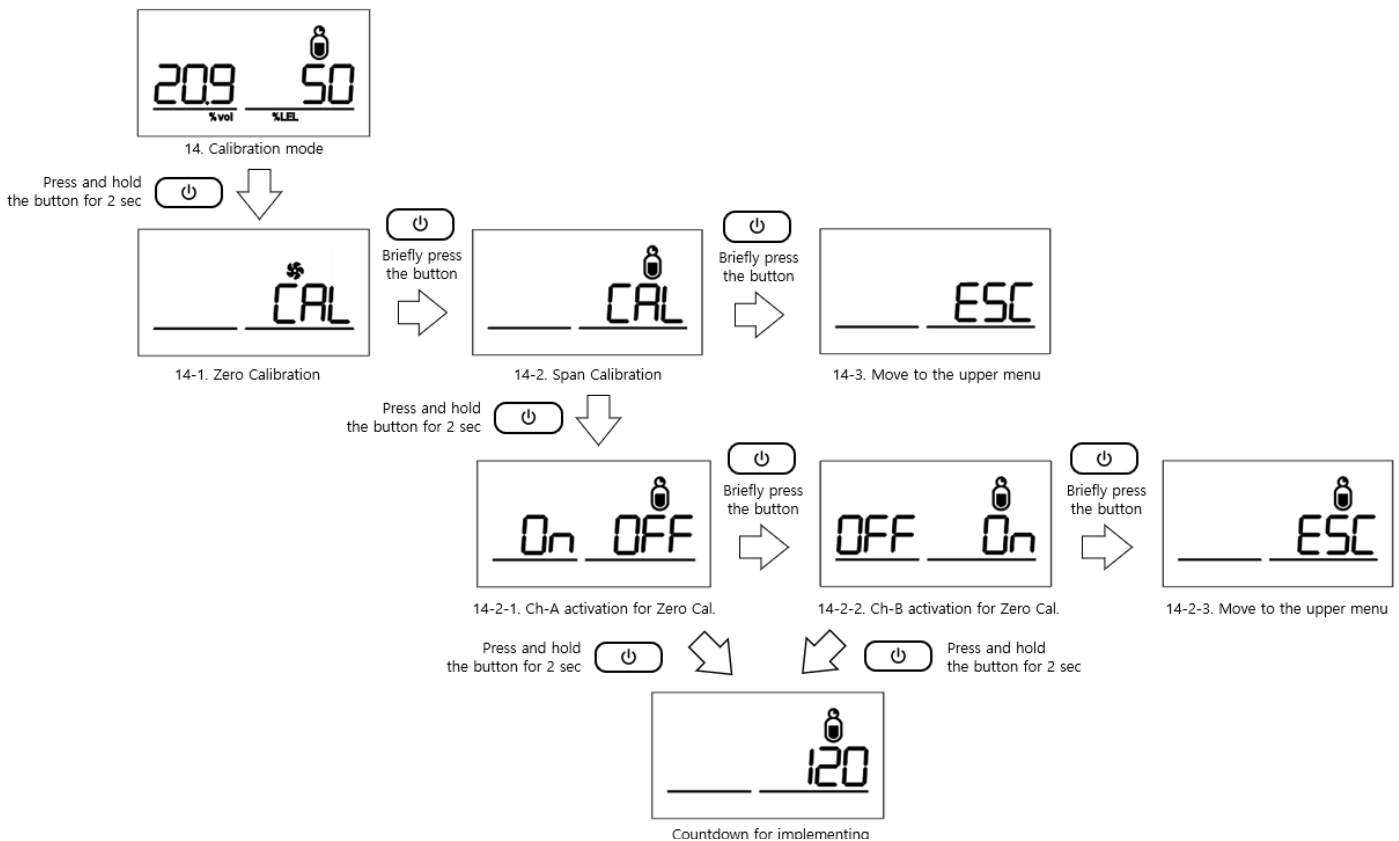

### 3.8. JUDGEMENT FOR IMPLEMENTING

Result for calibrating is on the display for each gas channel after implementing.

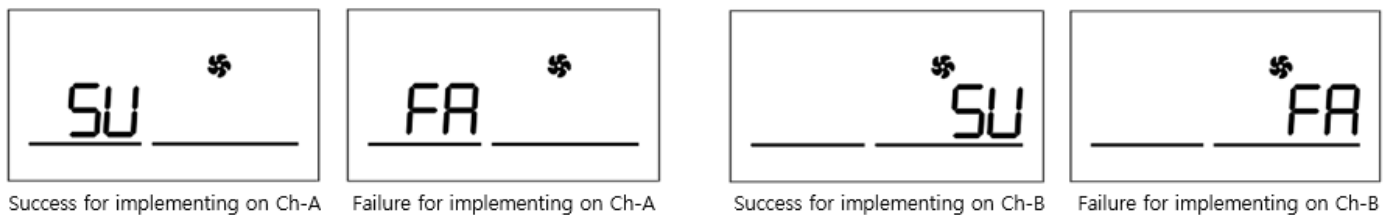

### 3.9. PEAK (MAX) VALUE

When gas is detected, the detector records the maximum exposure concentration. The recorded value can be cleared.

### 3.10. ALARM DISPLAY

The detector monitors gas concentrations and displays the alarm status when the gas concentration exceeds the alarm set point.

### 3.11. ACQUIRING ALARM EVENTS

Data stored in the detector's memory can be downloaded via IrDA. The stored information includes calibration events, LOW and HIGH alarms (including time of occurrence, duration, and gas concentration).

## 3.12.LOG

During operation, data, event, calibration, and bump test logs are stored. The stored data can be downloaded using WatchGas IR-LINK and a PC program.

Category	Details
<b>Event Alarms (High, Low, TWA, STEL)</b>	Time of occurrence, duration, alarm type, gas concentration, serial number
<b>Bump Test Logs</b>	Test date, success/failure, calibration gas concentration, detected concentration
<b>Calibration Logs</b>	Calibration date, type, calibration gas concentration, detected concentration
<b>Data Logs</b>	Date and time of IR-LINK execution, concentration, alarm type, options

## 4. ALARM / TEST FAILURE

### 4.1. ALARM FUNCTION

When the gas concentration exceeds the alarm set value, the alarm status is displayed on the LCD, and the device vibrates, flashes (LED), and emits a beep. To stop the alarm, move to an area with clean air, and the alarm will automatically stop.

Category	Details
<b>Gas Alarm</b>	The alarm set values are pre-programmed (primary, secondary alarms) at the factory. If the detector is exposed to concentrations above the upper limit, an OL (Over Limit) alarm is displayed on the LCD.
<b>Visual Alarm</b>	The LCD and three flashing LED areas will indicate when the gas concentration exceeds the alarm set value (primary, secondary alarms).
<b>Audible Alarm</b>	The programmed audible alarm is triggered when the gas concentration exceeds the alarm set value (primary, secondary alarms), and it emits a beep as a warning.
<b>Vibration Alarm</b>	The vibration motor activates when the gas concentration exceeds the alarm set value (primary, secondary alarms), providing effective warnings even in noisy areas.

### 4.2. ALARM SETTING VALUES

The default alarm set values are configured at the factory. Alarm set values can be adjusted either on the device itself or using the SP-IR LINK after activation. All alarm values are preset according to alarm standards required by international standards. Therefore, alarm values can only be changed under the responsibility and approval of the site manager where the device is used.



### 4.3. ALARM SOUND, VIBRATION, LED, AND DISPLAY (PER SECOND)

Category	Details
Low Alarm	The Low icon on the top screen is illuminated.
High Alarm	The High icon on the top screen is illuminated.
TWA Alarm	The TWA icon on the top screen is illuminated.
STEL Alarm	The STEL icon on the top screen is illuminated.

## 5. CERTIFICATION

### 5.1. EXPLOSION-PROOF CERTIFICATION

The detector is certified according to the following standards:

Model	X	Ch-A	Ch-B
IECEX	IECEX KSCP 24.0025X	PDM DUO-1 to 2 Ex ia op is IIC T4 Ga	IEC 60079-0:2017, Ed 7 IEC 60079-11:2011, Ed 6 IEC 60079-28:2015, Ed2
		PDM DUO-3 to 9 PDM DUO-A to F Ex ia IIC T4 Ga	
ATEX	KSCP 24ATEX0016X  	PDM DUO-1 to 2 Ex ia op is IIC T4 Ga	EN IEC 60079-0:2018 EN 60079-11:2012 EN 60079-28:2015
		PDM DUO-3 to 9 PDM DUO-A to F Ex ia IIC T4 Ga	
KCs	KGS XX-XXXXX- XXXX 	PDM DUO-1 to 2 Ex ia op is IIC T4 Ga	
		PDM DUO-3 to 9 PDM DUO-A to F Ex ia IIC T4 Ga	

### 5.2. MANUFACTURING APPROVAL

The detector manufacturer must comply with ISO 9001:2015 regulations.

## 6. PROTECTION RATING

The detector's IP Rating should be assessed as IP67.  
The product complies with Directive 2014/30/EC (EMC).

## 7. WARRANTY AND REPAIR

### WARNING

- Never replace the battery in explosive or hazardous areas.
- Replace the battery in a clean environment free of hazardous gases, as failure to do so may lead to severe accidents (serious injury or fatality).
- Replacing parts may invalidate the intrinsic safety features.
- Sensor and battery replacement should be performed by authorized dealers, distributors, or managers.
- Only sensors designated by WatchGas should be used for replacement.
- Disassembly is only necessary for sensor and battery replacement. After sensor replacement, a Span gas calibration must be performed.
- Before disassembly, ensure the power is turned off and remove the screws.

### 7.1. SENSOR REPLACEMENT

1. Deactivate the detector.
2. Remove the six screws from the rear cover.
3. Remove the two screws securing the PCB.
4. Flip the PCB over, remove the old sensor, and replace it with a new sensor.
5. Reassemble the PCB and rear cover.
6. After reassembly, perform Zero calibration and Span calibration according to the standards in this manual.

### 7.2. WARRANTY

The warranty period is 2 years from the date of purchase from the manufacturer or an authorized reseller.

The manufacturer is not responsible for defects if, upon testing and inspection, the product is found to be free of defects or if the defect was caused by misuse, neglect, improper installation, testing, or calibration by the purchaser (or a third party). Unauthorized attempts to repair or modify the product, or damage caused by fire, lightning, water, or other hazards, are also excluded from the manufacturer's responsibility.

If the product fails to meet the manufacturer's specifications during the warranty period, please contact the authorized reseller or WatchGas service center for repair/return information.



## 8. CONTACT INFORMATION

### EUROPE

Klaverbaan 121, 2908 KD Capelle a/d IJssel, the Netherlands

info@watchgas.com  
www.watchgas.com

### AMERICAS

313 N. State Hwy 342, Red Oak, TX 75154, USA

info@watchgasusa.com  
www.watchgasusa.com

### APAC

Woods Square Tower 1, 12 Woodlands Square, #11-71, Singapore 737715

+65 65179551  
info@watchgas.com  
www.watchgas.com

### ANZ

anz@watchgas.com

