



AIRWATCH MK_{1.2} USER MANUAL

Contents

Contents	2
Description	3
Warning	
Caution	3
Important	3
1 Product Overview	4
2 Description Mode	5
2.1 Backup Battery	5
2.2 Wireless Version	5
2.3 AirWatch Receiver	6
2.4 AirWatch Repeater	6
2.5 Beacon Sounder	6
2.6 Software	7
2.7 Application	7
3 Safety And Signalling	8
3.1 AirWatch Signalling	8
4 Transportation Storage, Assembly and Installation	9
5 Various Parts And Highlights	10
6 Operation	12
6.1 How To Use Magnetic Keys	12
6.2 Turning On or Off	12
6.3 Config (Configuration)	13
6.3.1 Unit ID	13
6.3.2 Flow Fault Adjustment	14
6.4 Cal (Calibration)	15
6.5 Bump	16
7 Relay Settings	17
8 Configuration Software	18
9 Operation and Troubleshooting	19
9.1 Alarm	19
9.2 Troubleshooting	19
9.3 User Maintanance	18
10 Turning The Device Off, Repairs and Disposal	20
10.1 Turning The Device Off	20
10.2 Repairs	20
10.3 AirWatch Disposal	20
11 Spare Parts And Accessoires	21
12 Specifications	22
13 Limited Warranty	23



Warning

- All persons responsible for the operation, maintenance and repair of this product must read this manual carefully. The product will function in accordance with the specifications only if it is operated, maintained and repaired in accordance with the manufacturer's instructions.
- The AirWatch is a safe device and may NOT be used in a potentially explosive atmosphere!
- Warranty: A one-year warranty applies to both the AirWatch and the sensors.



Caution

- If the filter is visibly dirty, it must be replaced before turning the AirWatch on.
- Check the pump after turning the AirWatch on. Close off the pump supply by covering the filter inlet with your finger. The pump will make three attempts (if setup to three attempts) to restart, and then the alarm will trigger.
- Only operate the AirWatch at temperatures of between -20°C and 45°C.
- Relative humidity: 0-95%, non-condensing. If sampling from any environment with different temperature or humidity, an evaluation shall be done and protection against condensation shall be installed. The AirWatch may only be turned off when no concentrations of explosive or toxic substances are present.



Important

STATIC ELECTRICITY DANGER: only clean the device with a moist cloth.

- This manual should be read by everyone who operates or monitors the watchgas gas detection system. Only personnel who have been fully trained by are authorised to Install, Set-up, Service, and Test, Repair, or Recondition the system.
- All new devices are calibrated by factory when they are delivered. The AirWatch requires regular maintenance: we recommend having it calibrated and maintained every six months.
- A bump test assesses the sensors' responses to test gas.
- Special calibration gas is needed for carrying out bump tests. This is available from your distributor.
- The device must be used in accordance with the AirWatch sensor configuration. Testing it with different or non-recommended gases may seriously damage the sensors, and testing the LEL sensor with a cigarette lighter will result in irreparable damage. Improper use can create a dangerous situation.

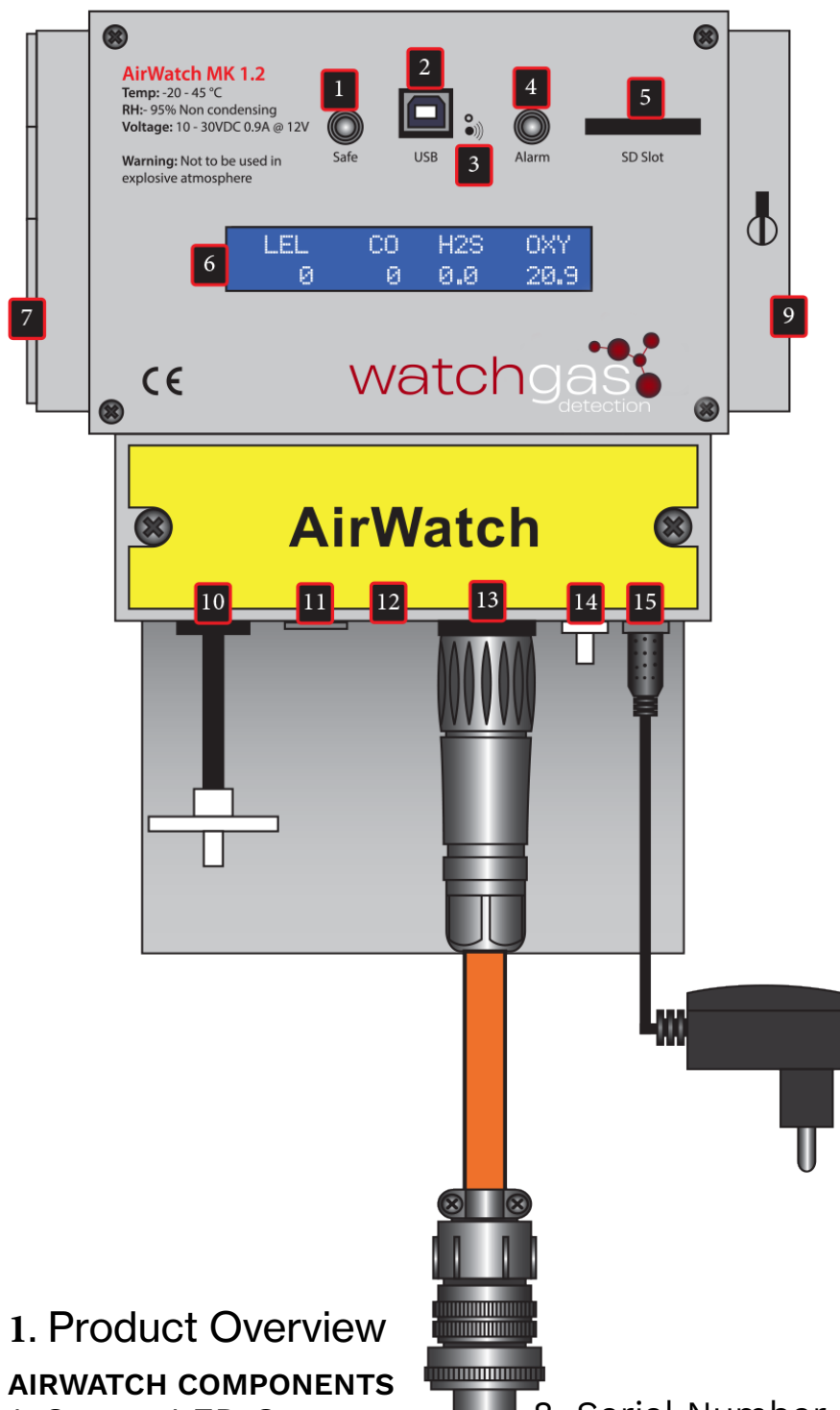

1. Product Overview

AIRWATCH COMPONENTS

- | | |
|---|--|
| 1. Status LED Green | 8. Serial Number |
| 2. USB | 9. Alarm reset and contact B
(with use of magnetic key) |
| 3. Status LED Wireless Blue | 10. Gas Inlet |
| 4. Status LED Red | 11. Modbus RS 485 |
| 5. SD Card Slot | 12. Cable gland Precut |
| 6. LCD display | 13. 7-Pins Connector DC Power in Relay out |
| 7. On/Off and contact A
(with use of magnetic key) | 14. Gas Outlet |
| | 15. DC Desktop (only use for maintenance) |

2. Description & Mode Of Operation

For the purpose of measurements in atmospheres containing steam, a condensate separator must be placed between the inlet filter (PN SEI-AAC-TA03-T00SE) and the measurement hose (PN 8719992974788).



The AirWatch can detect many different kinds of gasses, for example:

1. Flammable gases are measured with a catalytic sensor or NDIR sensor.
2. Hydrogen Sulphide, Carbon Monoxide, Oxygen and toxic gases are measured with electrochemical sensors.

2.1 BACKUP BATTERY

The AirWatch is externally powered from a battery or DC supply (10-30V dc, max. 900 mA @ 12Vdc). If the external power supply fails, the backup battery can continue providing power to the AirWatch for up to 60 minutes. This time can be adjusted with the configuration software (which can be found on the download page of www.watchgas.eu). With the optional wireless function the AirWatch sends a signal when it switches from the external power supply to the backup battery. The operator can then take action to restore the external power supply.

When the AirWatch is connected to a power supply, the backup battery will charge. The LED's will indicate the state of charge.

Blinking RED > Charging

Blinking Green > Fully charged

Continuously RED > Backup battery Error

The backup battery also ensures that the sensors continue to receive power when the AirWatch is switched off. This ensures that the measurement accuracy of the sensors is maintained. If an AirWatch is stored for a longer period of time we recommend connecting the included 12V adapter in order to ensure the sensors are always ready to be used in the field and keep the warm-up time short.

2.2 WIRELESS VERSION

Optionally, the AirWatch can be equipped with a wireless module to enable wireless communication with other AirWatch devices within a mesh network. If multiple (up to 50 pieces) AirWatch devices are linked in a wireless network, they can all turn on at an alarm from one device, if they are set in this way.

The AirWatch Wireless network can be used with a central receiver connected to the Monitoring software.

Another possibility is to use several AirWatch devices in a Stand alone network without use of a computer. In a stand alone network if one device goes in alarm the other device will also give a alarm signal.

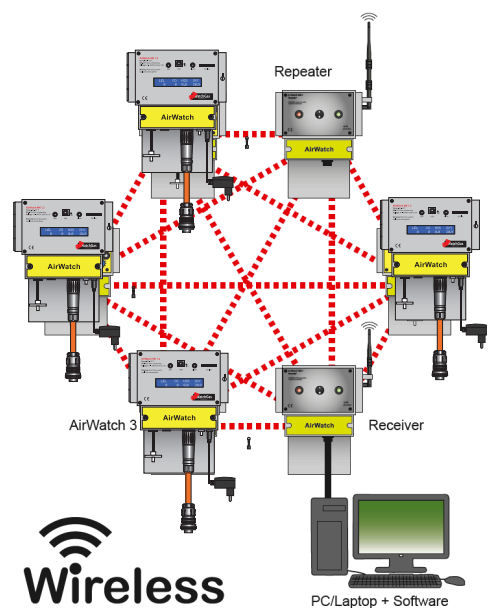

Wireless
AirWatch mesh network with one receiver, one repeater and four AirWatches.

2.3 AIRWATCH RECEIVER

It is therefore possible to turn off up to 50 machines at once when an alarm occurs. The optional wireless communication functions at a frequency of 2.4 GHz within a mesh network.

The mesh network ensures that all devices also function as repeaters and share data. The maximum line-of-sight transmission distance between devices is 300 metres. If necessary, repeaters can be placed within this wireless network to further increase the distances.

There is also the option of bridging larger distances using special directional antennas. Additionally, there is the option to display all data generated by the AirWatch centrally on a laptop or PC and to store this data. In case of an alarm, this will also be visible on the PC.

The network functions at a frequency of 2.4 GHz which has a 300-meter transmission distance. Distances of up to 500 meters can be achieved with special antennas.

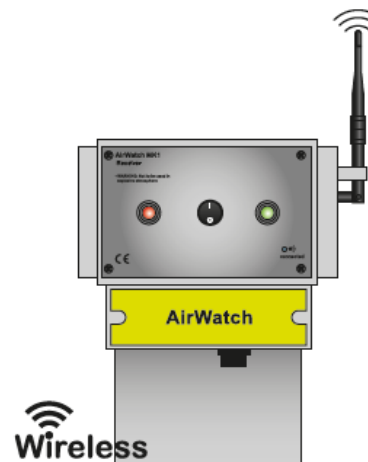

AirWatch Receiver

2.4 AIRWATCH REPEATER

In order to avoid blocks in the connection due to obstructions (towers, bridges, pylons etc), repeaters can be placed in the network. In this way you can substantially increase the size of the network.

The use and number of repeaters is unlimited, and the AirWatch itself functions as one. The blue LED on the AirWatches and repeaters shows that they are communicating with the receiver (master) that is connected to the PC.

If AirWatches or repeaters go offline, the system activates an alarm. If they come back online, the system resets itself.



AirWatch Repeater

2.5 BEACON SOUNDER

The AirWatch can optionally be equipped with an Beacon sounder. This can be desirable in an area with a lot of ambient noise or better visibility. The built-in sounder gives a signal of at least 107 dB, and the bar has red and green LEDs that are visible from 360°. In normal measurement mode, the green LED will be on. In case of an alarm, the red LED will flash and a signal will sound. The standard AirWatch LED and display signalling will remain normally visible in this configuration.

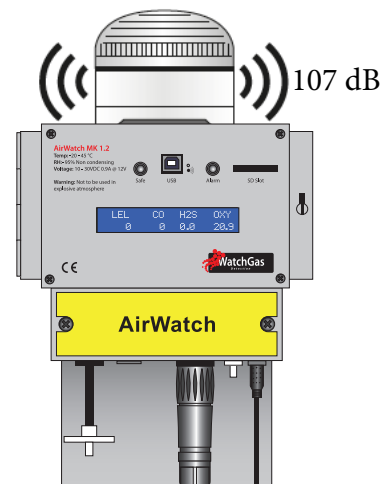

AirWatch with optional Beacon Sounder

2.6 SOFTWARE

The specially developed monitoring software for the Wireless AirWatch, which you can find on www.WatchGas.eu, can be used for many different purposes, for example in process control rooms, CCTV monitoring, and issuing work permits. The real-time data from the AirWatches enters via an additional PC or laptop. If an alarm or report is received, the system gives a visual and an audible alarm and full details are given on the screen so you can quickly take action. Early warning is key here!

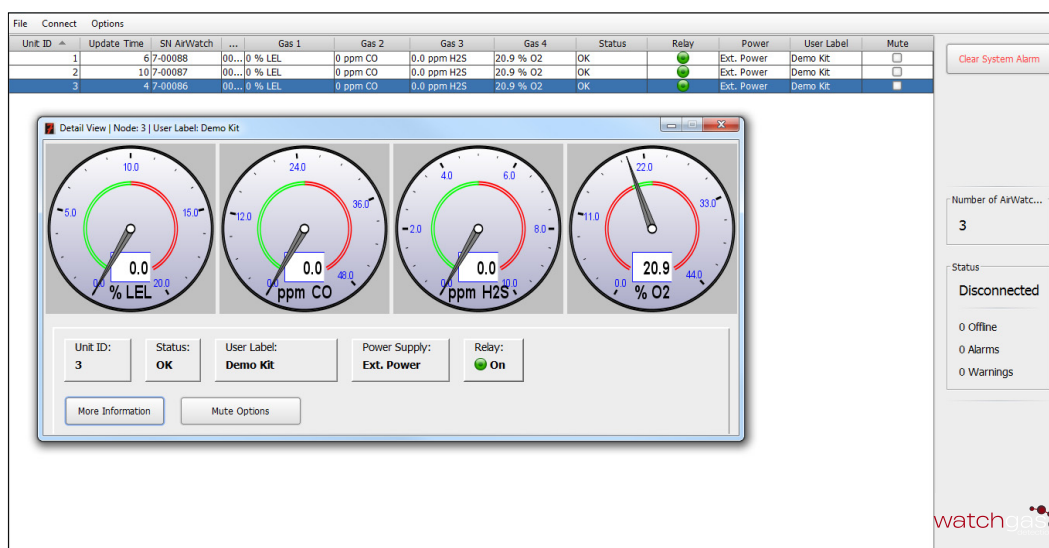

2.7 APPLICATION

One of the safe applications that the AirWatch can be used for is the monitoring of breathing air when compressors are being used. When hazardous substances are measured, the AirWatch will turn the compressor off immediately, so that no harmful substances can get into the air bottles. If the concentrations detected have dropped to below the alarm limits, the AirWatch can be reset and the equipment attached to it restarted. The AirWatch will continue to measure the surrounding air during and after use. This application is also suitable for generators, welding transformers and pumps.

Check availability of software and application notes of the AirWatch at www.watchgas.eu or get in touch.



3. Safety And Signalling

Read the manual and quick start guide before use. The applicable regulations must be complied with at all times when carrying out repairs on these devices or parts. Repairs to the device may be carried out only by trained staff in accordance with the AirWatch maintenance instructions. The AirWatch is only suitable for safe area applications.

The response times mentioned in this manual are our recommendations. If response times are also issued by the organization where the AirWatch is in use, then those are binding.

The response times mentioned may differ from the tested times for a variety of reasons

Warning

The AirWatch should definitely NOT be used in a potentially explosive atmosphere!

3.1 AIRWATCH SIGNALLING

The AirWatch is equipped with LED signalling. The LEDs are specially developed to maintain their visibility from long distances, and in fog, rain, snow or bright sunlight. You will find the following signalling on the AirWatch:

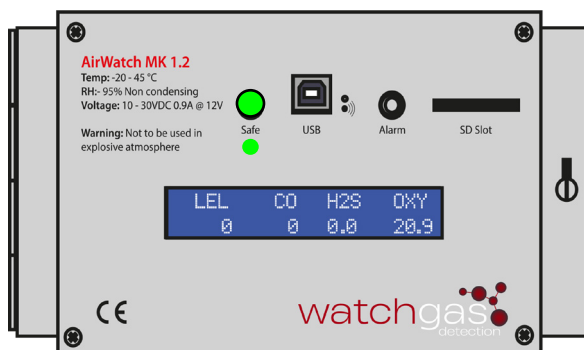

Green LED. AirWatch is turned on and functioning



Red LED. The AirWatch alarm is activated. A gas concentration higher than the alarm values has been detected, or the pump is blocked.

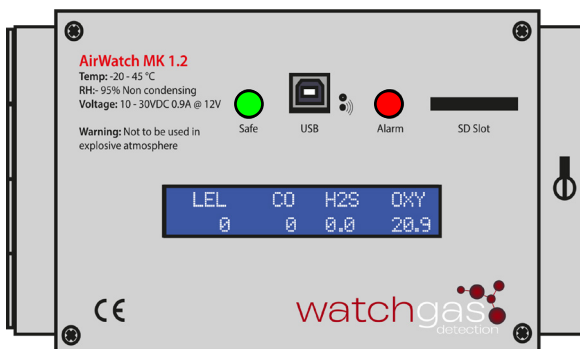

Red LED is on continuously and green LED is flashing. The AirWatch can be reset with the alarm/ reset button.

4. Transportation, Storage, Assembly And Installation

The following storage and transportation requirements must be complied with:

- Store in a dry and clean environment.
- Transport in the appropriate case or packaging.
- Do not expose to high temperatures.
- Avoid dropping and/or bumping.
- Remove contaminations from the AirWatch immediately.
- Storage temp 0 - 45 degrees 0-95%RH



AirWatch with accessories.

If the AirWatch is not in use, we recommend storing it attached to the included 12-volt adapter. When you need the AirWatch, disconnect it from the adapter and it will be immediately ready for use. If it has not been connected to a power source for a long time, we recommend letting it stabilize first, by starting it in a dry and clean environment and running it for 60 minutes.

Then carry out a fresh-air calibration in a clean environment and the device will be ready for use. For optimal measurement accuracy, the electrochemical sensors should be allowed to warm up.

Assembly and installation

The AirWatch basic equipment consists of the following components:

- AirWatch
- 12V DC adapter
- English quick reference card
- Connection cable; cable type 1 or 2. See page 19.
- 2x Magnet keys

Minimum requirements for the placement of the product:

- The AirWatch is equipped with magnets and can be attached to metal. The location selected should be able to support its weight (2,000 grammes).
- Install in a safe place where it does not obstruct doors, walkways etc.
- After the AirWatch is assembled, attach one end of the connection cable to the bottom of the unit, and the other to a MSA connection, or directly to a battery using battery clamps.
- Turn on the AirWatch and let it run through the boot menu. See page 11.
- Carry out a fresh-air calibration, and a bump test.

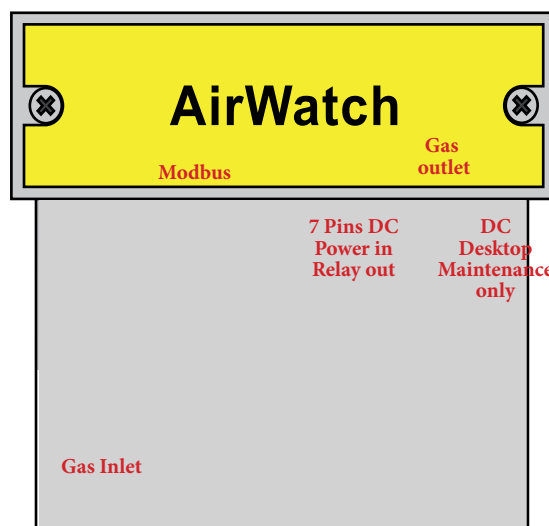

Bottom of AirWatch with Gas inlet, Modbus, 7Pins DC Power in Relay out, Gas outlet & DC Desktop (Maintenance only)

5. Various Parts Highlighted

PUMP (ART.# 501213/ 501214)

The pump has large valves. If you replace the filters regularly and on time, it will enhance the lifespan of the pump. On average, it will last at least 5,000 hours, and may be replaced only by trained personnel or by request your distributor.

FILTERS (ART.# HW-008-3022-010M FOR 10 FILTERS OR HW 008-3022-0100M FOR 100FILTERS)

It is essential that the AirWatch must always be used with the 0.22- micron PTFE filter supplied. This filter is installed at the bottom of the device. Without it, dirt and dust can be sucked into the device and damage the pump, electronics and sensors. The external filters must be replaced regularly: how often depends on the environment in which the unit is being used. Steam and dust shorten the lifespan of the filter. Filters are available from your distributor.

LIGHTING

The AirWatch has a backlight display so that it is visible in dark areas or when built in to a machine. The protective cover must be kept closed as much as possible to keep out moisture and dirt. The activation buttons are located outside of the protective cover, so they too, are moisture and dirtproof.

RS485 MODBUS

RS485 is a serial communication method for PCs and other devices. It is widely used where multiple data acquisition and control systems communicate with each other. The AirWatch is equipped with it as standard, and is available through 3 pins connector (art.# 501143). Protocol available on www.WatchGas.eu or ask your distributor.

NOTE: If the AirWatch is equipped with a wireless module you have to choose between using modbus or wireless.

DELAY TIME

The AirWatch has a delay time of 0-60 minutes (this can be configured with configuration software, which you can find on www.watchgas.eu). With a delay time, it will continue to measure after the machine has been turned off and while the engine and exhaust remain hot. When the preset time has elapsed, it shuts down.

PROTECTIVE COVER

The cover has multiple functions, protecting the AirWatch against dust and moisture and against use by untrained personnel.

DATA LOGGING

Datalog is basic. The datalog interval can be setup with the configuration software. SD cards for the data logger and configuration files can be inserted in the appropriate slot, making it easy to configure your device for a different application. The SD card can easily be removed by opening the protective cover and carefully pressing the card with one finger until it pops out. The SD can be read using your computer. To read the card, select it in Windows Explorer and open the 'logs' folder to view log files arranged by date and in text format. This data can be imported into Microsoft Excel and other tools. A 4GB SD card will be full in approximately 166 days if the data logging interval is one second.

NOTE: If the files are not arranged by date, click on 'last modified' and the latest data will appear at the top.

HOUSING

The electronics and components in the AirWatch are protected by a robust IP65 housing with reflective contrast areas on the outside to enhance its visibility. The metal mounting plate also serves as protection for the connections on the bottom.

LAST-O-MORE HOSE (ART.# 8719992974764) AND BALLFLOAT (ART.# 8719992974764)

If you are going to carry out a measurement at a distance from the device, for example in a confined space, you must use our WatchGas Last-o-More sampling hose (3x5 mm Art.Nr. 411 0018 038 and 5x8 mm Art.Nr. 411 0018 039) and our WatchGas Ball float. When you carry out a measurement in this way, there is a delay of approximately three seconds per linear metre of hose.

FLOW REGULATOR (ART.# CAL-C000001)

For bump test and calibration a demand flow regulator is recommended, for the toxic gases we recommend to use a stainless steel flow regulator 1.0 lpm with use of an t piece see figure below the demand regulator on a gas bottle ensures the correct quantity of gas necessary to carry out a calibration or bump. Because the pump creates a vacuum, the regulator will release the gas, enabling it to flow over the sensors. The supply is demand-based to prevent the loss of gas.

For good bump results, the system must be leakproof. Connect the hoses tightly and screw the regulator onto the bottle so that it is straight. The connections should be hand-tight, so do not use wrenches, pliers etc.

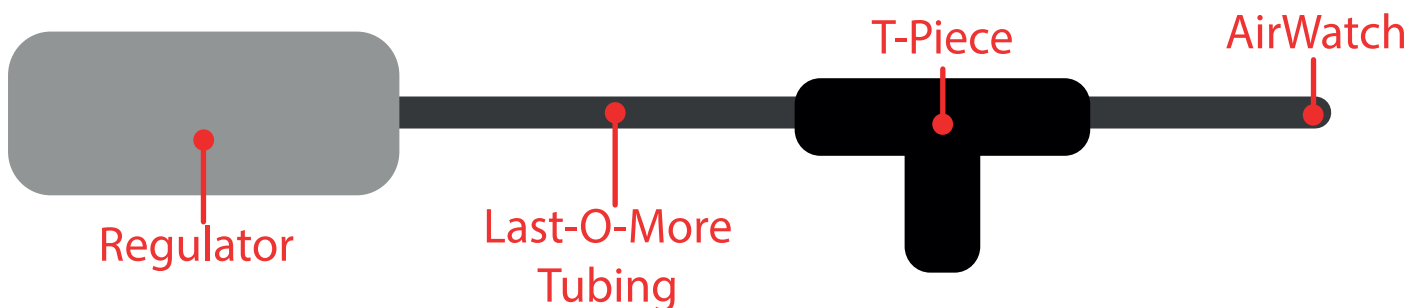

6. Operation

6.1 HOW TO USE MAGNET KEYS

When turning on the AirWatch, the cable between the AirWatch and the machine must be connected. When the boot menu has been completed, the red LED will come on and the green LED will start flashing. Activate alarm/reset (Contact B) to put the AirWatch in measurement mode and start up the machine. We recommend having it checked and calibrated every six months.

Keep “on/off” active for three seconds to automatically start the AirWatch. Starting takes a maximum of 250 seconds and will stop earlier if the sensors are warm.

The display will then read ‘Fresh air calibration’. When you are sure that you are in a safe environment, select ‘Yes’.

Warning! If you are not sure, select ‘No’.

1. The AirWatch will now carry out a fresh-air calibration for up to 250 seconds.
2. Activate the ‘alarm reset’ to switch to measurement mode.

After the startup procedure, test the pump by blocking the filter inlet. The AirWatch will take three attempts if configuration is setup to this. To start the pump before generating a pump alarm. To cancel this, unblock the inlet and activate “alarm/reset”.

The AirWatch is ready to use.

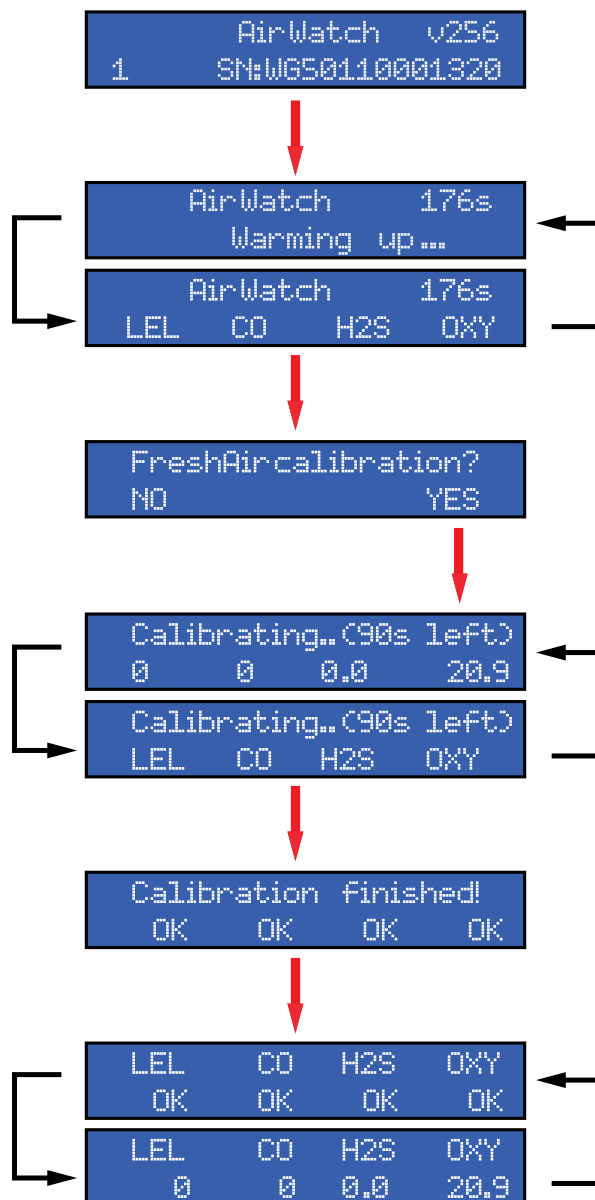

6.2 TURNING ON OR OFF

1. Hold a magnetic key on the left side (contact A) against the AirWatch in order to turn the AirWatch on and off.
2. Hold a magnetic key on the right (contact B) side against the AirWatch in order to activate Alarm reset on the AirWatch.

Once the AirWatch is turned on and operating, you can select various menu options, such as a fresh-air or span calibration, or bump test. Do this as follows: For all three functions, start by displaying the menu.

Activate both buttons until the message 'enter password' appears. Enter the password (default is 1234) and select >. Then you have three choices:

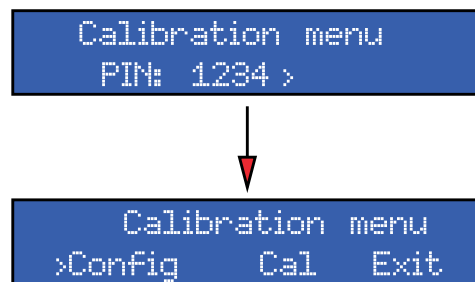

6.3 CONFIG (CONFIGURATION)

6.3.1 UNIT ID

This allows you to assign an ID number to the AirWatch so that you can recognize it when using multiple units. This applies only to the wireless and modbus RS485 functions. Don't use same numbers in one network setup.

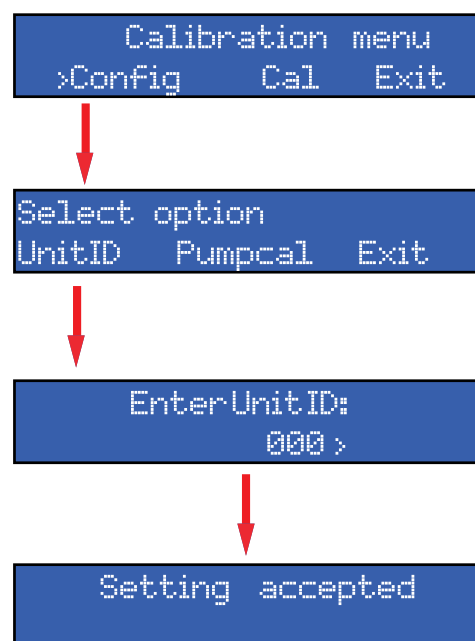

6.3.2 FLOW FAULT ADJUSTMENT

The AirWatch can detect if there is enough flow to perform a good reading.

Default password is 1234 can be changed by use of the configuration software.

To set the limits for under and upper flow you can adjust it, for example if there's a new longer/shorter tube connected.

To adjust flow fault upper and lower settings follow the procedure below entering the manual menu.

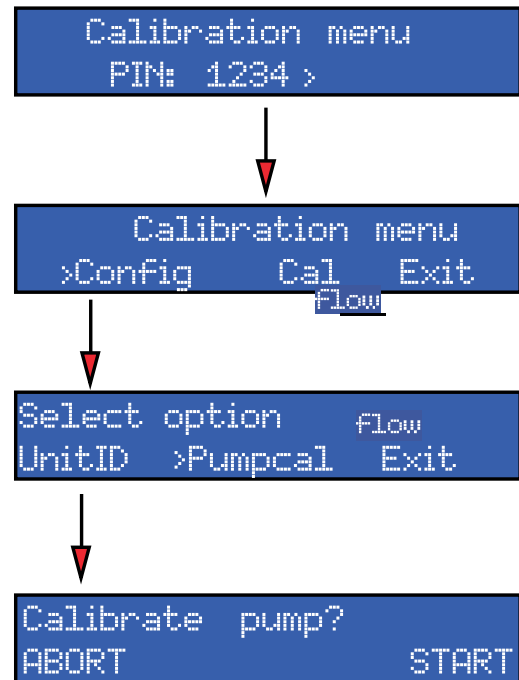

6.4 CAL (CALIBRATION)

You can select from 'Fresh, Bump, Span, Exit' here. If you select 'Fresh', the AirWatch will carry out a fresh- air calibration. Select 'Start' to confirm your choice.

If you select 'Span for a calibration'. Connect the calibration gas to the filter inlet and select 'Start' from the menu. The AirWatch will carry out the calibration, which lasts 90 seconds, and then state 'Calibration finished'. Disconnect the gas and select 'OK'. The AirWatch is now calibrated.

NOTE: A span calibration must only be carried out by trained personnel. If this is not done correctly the device will no longer function properly. This may result in dangerous situations.

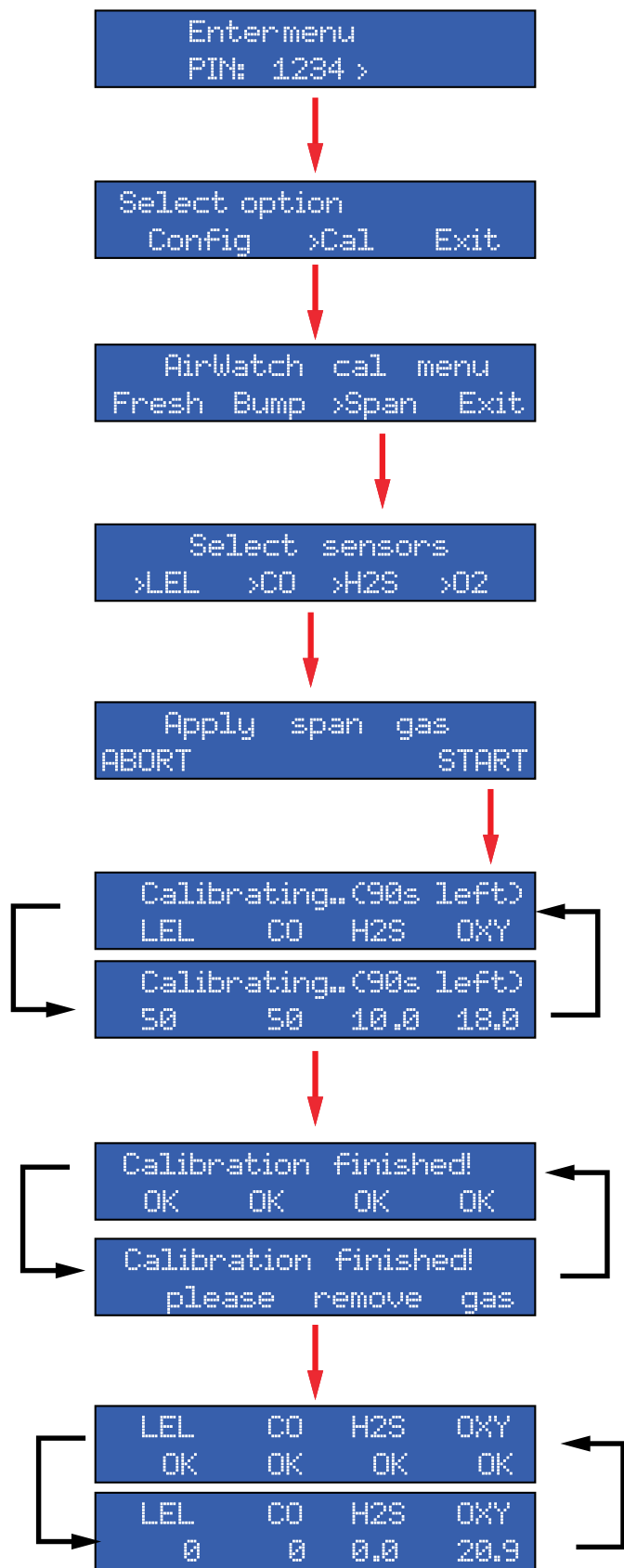

6.5 BUMP

Select 'Bump' in order to test the sensors. The AirWatch will ask you to apply the gas. Please confirm that you test gas contains the same concentration as the span values of the AirWatch, the Bump Test algorithm expects the same concentration to be applied. After 30 seconds, the results will appear and the AirWatch will prompt you to remove the gas.

Note for 6.4 and 6.5

Select sensor by using magnetic keys on contact "A and B".

In order to confirm your choice, hold "Contact A" for a while.

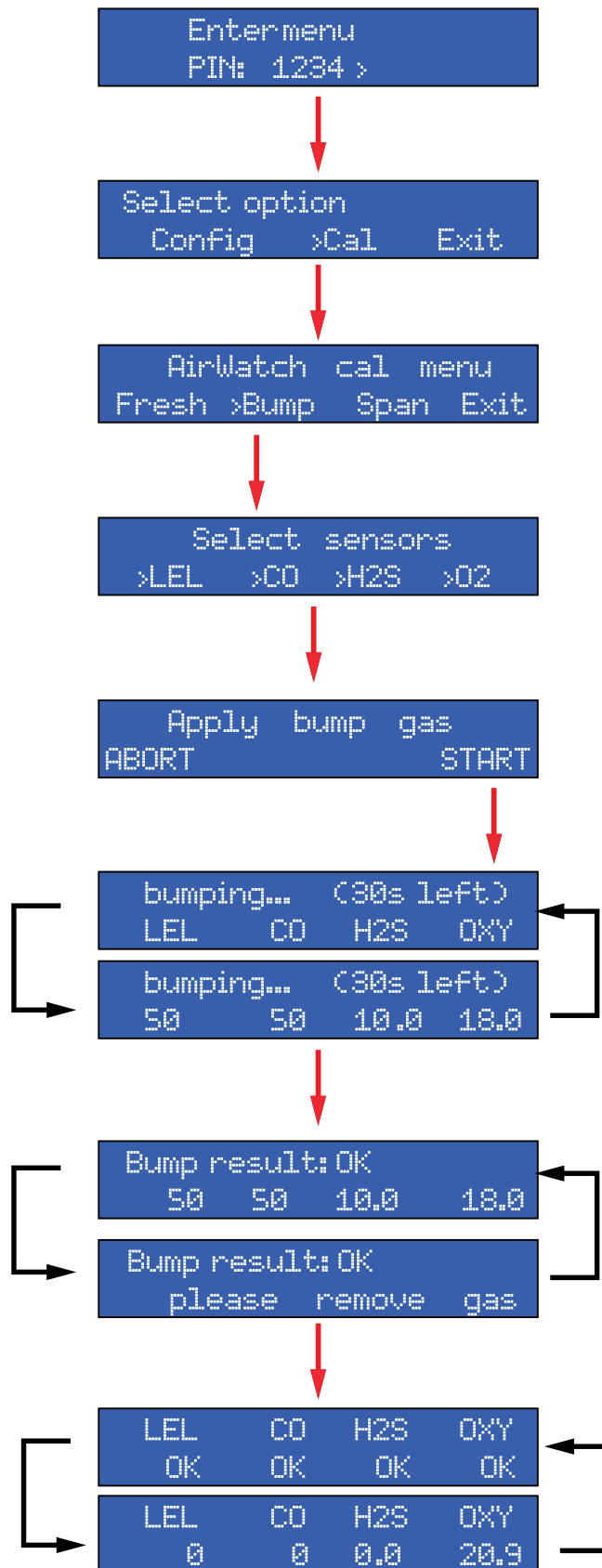

7. Relay Settings

The AirWatch contains 3 relays which can be setup with the configuration software independently. All of the relays can be setup to react on specific settings, be always energized or not.

Rating is 24V DC 2A maximum.

The relay's have numbers 0, 1 and 2. Number 2 is basic wired to the 7 pins connector and used for cable type 1 or 2.

The other 2 relays you can use by adding a cable gland (0.5mm 2 to 2.5mm 2).

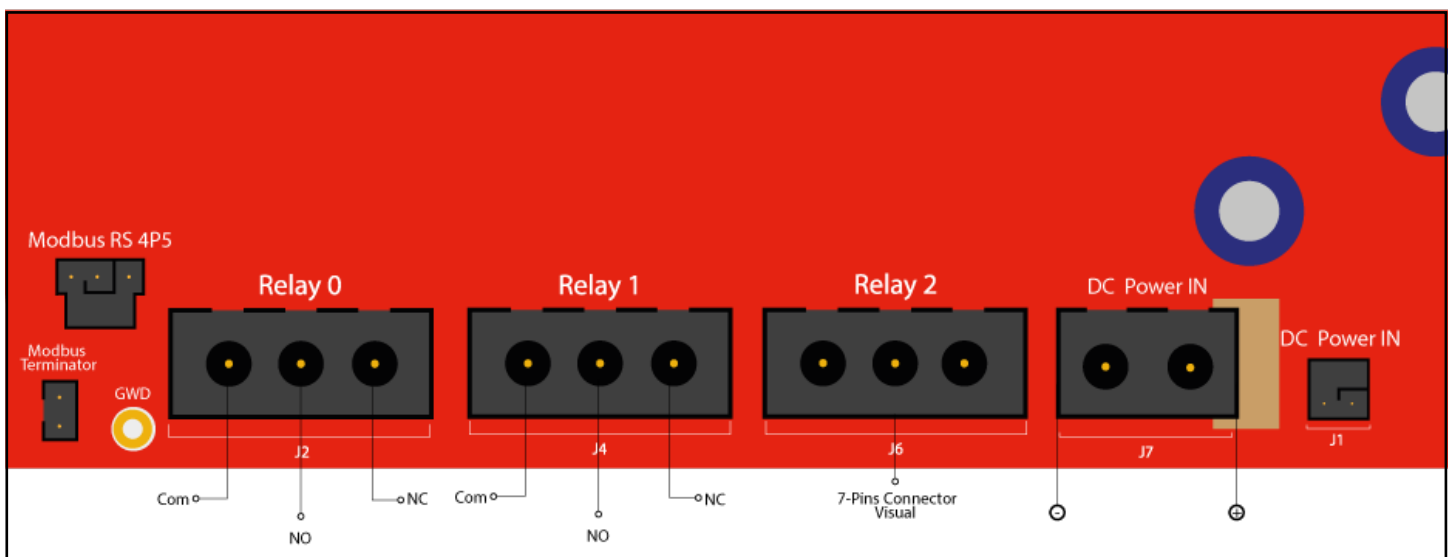

Basic Relay Settings: in basic configuration Relay 2 will be setup as a energised relay.

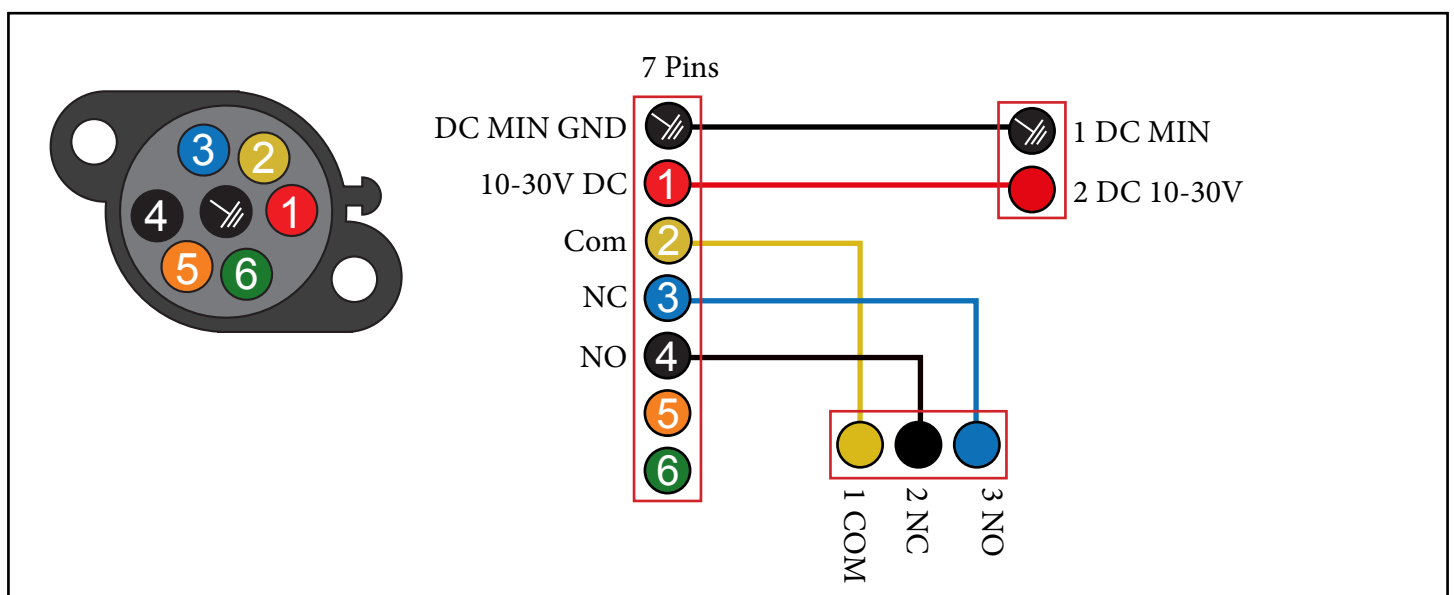

7-Pins Connector Visual.

8. Configuration Software

To setup all features en functions of the AirWatch please download and install our configuration software, which is available on our WatchGas website.

With the configuration software you can change the alarm levels, setup pin codes, select sound and colors for the optional Beacon Sounder, setup the relays and many more options.

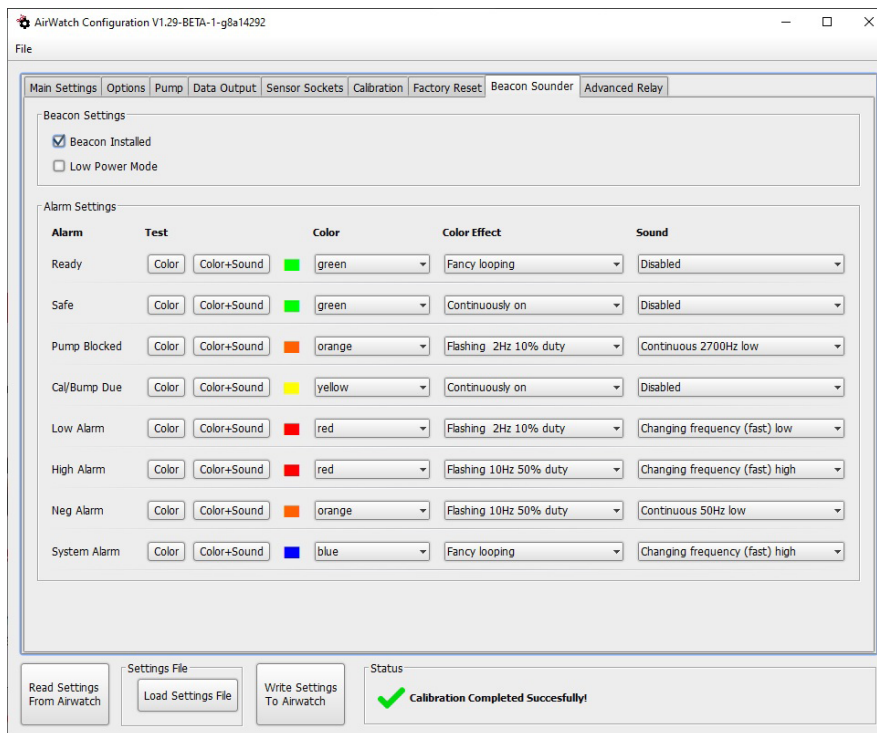

Configurator Beacon Sounder

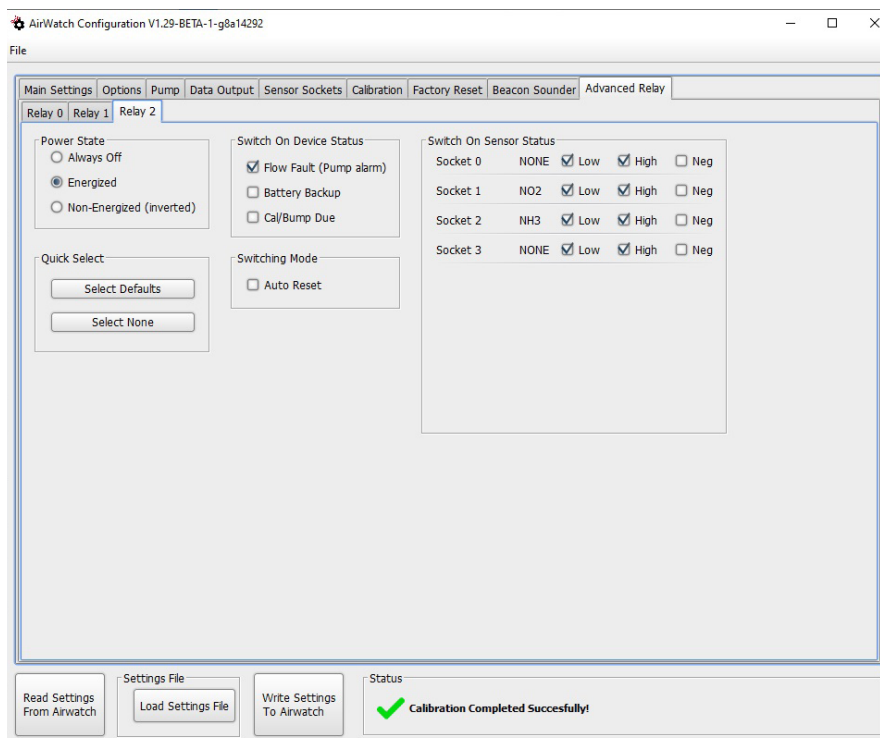

Configurator Relay

9. Operation And Trouble shooting

9.1 ALARM

When the AirWatch detects a dangerous concentration of gas, it will break a potential-free contact, using an M.S.A (Motor Stop Automatic) plug to turn off a diesel-operated or an electric switch box. A red light on the AirWatch indicates that there is an alarm.



Red LED. The AirWatch alarm is activated. A gas concentration higher than the alarm values has been detected, or the pump is blocked.

recommend having the area inspected by an authorized gas analyst. The AirWatch can only be reset after the concentrations measured have dropped below the alarm values. When the default values appear again, reset the alarm. The red LED is on continuously and the green LED is flashing. This reset is achieved by holding down the alarm reset button. This option is configurable, and we recommend a manual reset if you are using a power unit or breathing air machine.

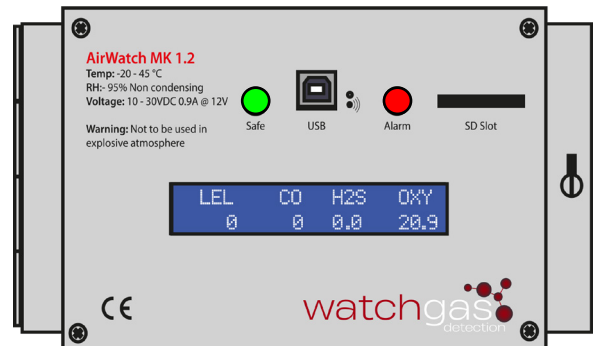

Red LED is on continuously and green LED is flashing. The AirWatch can be reset with the alarm/ reset button.

AirWatches with a wireless option will carry out an automatic reset when the values have dropped below the alarm threshold.

10.2 TROUBLESHOOTING

1. Error calibrating. The sensors are unstable during the calibration procedure. Repeat the calibration process. Incorrect calibration gas. If the problem occurs repeatedly, contact your distributor.
2. Sensor fail. Sensor(s) are not recognized by the device. Restart the device and if the problem occurs repeatedly, contact your distributor.
3. NEG alarm. Unstable sensors. Have the device stabilized and carry out a fresh-air calibration in a safe and clean environment.
4. Pump Blocked. Supply hose or filter is blocked. Remove the blockage and press 'alarm reset' to reset the alarm.
5. Bump Fail. Incorrect bump gas, sensors unstable. Repeat bump test. If the problem occurs repeatedly, contact WatchGas.
6. Invalid Configuration. Try to reconfigure your device with the configuration software if problem occurs repeatedly contact WatchGas for repair
7. If the Green and RED LED indicators are blinking RED>GREEN>RED>GREEN there's a lockup detected and the AirWatch prepares to reboot.

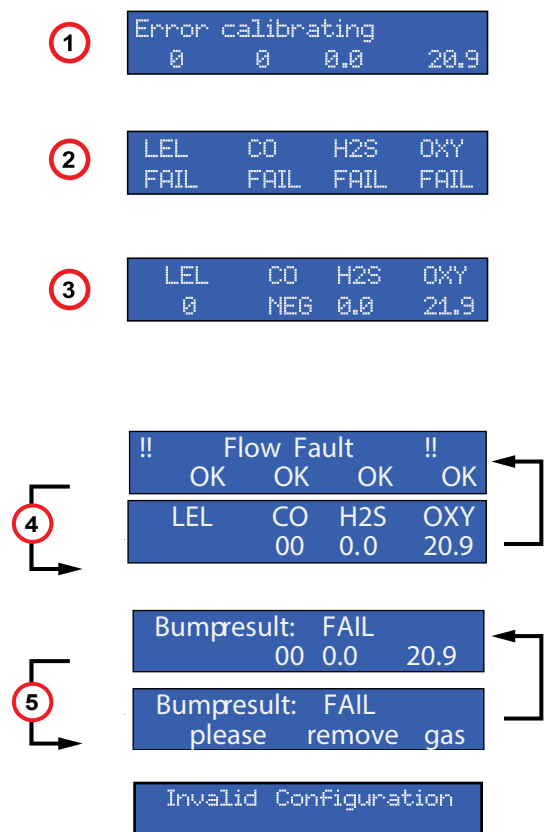

9.3 USER MAINTENANCE

The maintenance that can be carried out by the user is as follows:

- Bump test
- For more details on this, see chapter 7, Operation.
- Check the filter regularly, and replace it if dirty.
- The filter keeps out sand, dust, fluids and other contamination that may affect the accuracy of the measurements or irreparably damage the pump, electronics and sensors.
- While replacing the filter, turn off the AirWatch to prevent sand, fluids, dust etc. from getting into the pump and stopping the device from functioning.
- You must replace the filter in a clean environment with clean hands. The filter should always be stored clean, dry and dust-free in the packaging intended for that purpose.
- Turn the filter counter-clockwise to disconnect it from the hose.
- Take a clean filter from the plastic bag and turn it clockwise to attach it to the hose.
- After replacing the AirWatch you must carry out a fresh-air calibration if environment allows you to.
- Clean the unit with a damp cloth, and never use solvents or abrasive cleaning agents.

Maintenance by trained personnel:

Trained personnel may carry out the following activities. Everything has been described under ‘User maintenance’.

- Conducting a span calibration.
- For more details on this, see chapter 7, Operation.
- Internal filter replacement. See page 12.
- Unscrew the front cover of the AirWatch using a Phillips screwdriver.
- Detach the hoses from the filter and install a new clean filter.
- Reattach the front cover.
- Turn the AirWatch on and carry out a fresh air calibration.
- After the AirWatch has been started, carry out a pump test. Contact your supplier or WatchGas to obtain bump test equipment, flow regulators, bump gas cylinders and hoses. Also see chapter 6, Various Parts Highlighted for more information.

10. Turning The Device Off, Repairs And Disposal

10.1 TURNING THE AIRWATCH OFF

The AirWatch may only be turned off when no concentrations of explosive or toxic substances are present.

1. Activate on/off for approximately two seconds and enter code 4321.
2. Activate on/off to increase the number.
3. Use the alarm/reset button to move on to the next number.
4. Then select > and select the alarm/reset confirmation button.

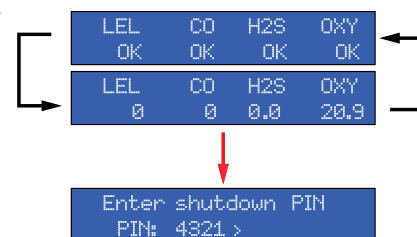

In order to maintain measurement accuracy and start up the device quickly, we recommend that you keep it connected to the 12V DC adapter when it is not being used for an extended period of time. The optional backup battery will keep a current running through the sensors when it is turned off. If necessary, store it in the case or packaging provided.

10.2 REPAIRS

The external filter(s) may be replaced by the user. The internal filter may be replaced only by trained personnel. See also page 15. For safety and warranty reasons, all other maintenance, such as sensors, pumps and electronic components, must be carried out by WatchGas.

Internal and external modifications to the device can be dangerous, and are prohibited. Should a defect occur, you can contact our service department.

The AirWatch should only be used for the intended purpose.

10.3 AIRWATCH DISPOSAL

Dispose of materials in accordance with the relevant legal requirements. You may return the unit to us for safe dismantling and disposal.

AirWatch connection cable type 1.

Amphenol female 7 pins molex

Earth	DC negative
1	DC positive 9/36vDC
2	Com
3	NC
4	NO



Cabel & Wiringnumbers

Y/G	DC negative
1	DC positive 9/36vDC
2	Com
3	NO
4	NC



Amphenol male 6 pins

A	DC positive 9/36vDC
B	DC negative
C	
D	NO
E	Com
F	NC

AirWatch connection cable type 2.

Amphenol female 7 pins molex

Earth	DC negative
1	DC positive 9/36vDC
2	Com
3	NC
4	NO

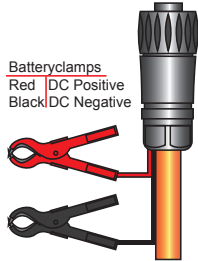

Batteryclamps
Red DC Positive
Black DC Negative

Cabel & Wiringnumbers

Y/G	DC negative
1	DC positive 9/36vDC
2	Com
3	NO
4	NC



Amphenol female 3 pins

A	Com
B	NO
C	NC

AirWatch chassisconnector

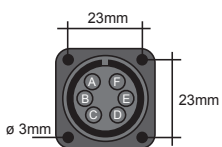

Connector female 6 pins

A	DC positive 9/36vDC
B	DC negative
C	
D	NO
E	Com
F	NC

Connector dummycaps. 3 female & 6 male pins



Amphenol male 6 pins

A	
B	
C	
D	
E	Bridged
F	Bridged

Amphenol female 3 pins

A	Bridged
B	
C	Bridged

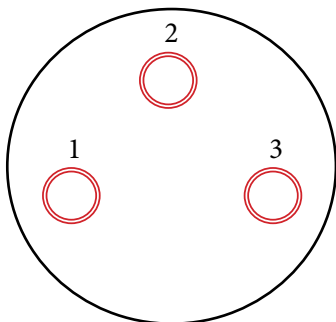

1. Modbus B
2. GND
3. Modbus A

Pin out of the 3 pins modbus connector

11. Spare Parts And Accessories

The following parts can be ordered or, in some cases, built in to the AirWatch at a later stage. Contact us for details.

- Case
- Last-O-More Gas Sampling Hose + Ballfloat
- Calibration gas
- Demand flow regulator
- AirWatch calibration equipment
- Water trap/dust filters
- SD card
- Condensation separator
- 230V to 12V adapter
- Battery backup
- 5,000-hour pump
- Receiver for communication between PC, laptop and AirWatch.
- Mesh network repeater.
- Beacon Sounder. Fitted with an acoustic (107 dB) and visual signal
- Battery trolley with battery monitor
- AirWatch type 1 connection cable
- AirWatch type 2 connection cable with battery clamps
- 6-pin Amphenol case for inclusion in the device when it is to be turned off
- Dummy cap to cover the Amphenol case.
- Power Shutdown Unit
 - 16-amp stop button
 - 32-amp stop button
 - 63-amp stop button
 - 125-amp stop button
- O₂ Sensor
- LEL Sensor
- CO Sensor
- H₂S Sensor
- Magnet Keys



Magnetic Keys

Other types of sensors on request.

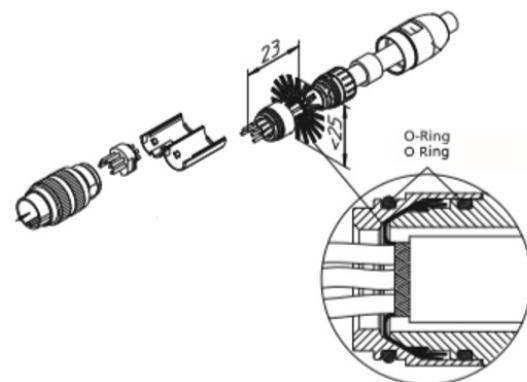

Modbus Connector assembly
P/N: 501138

12. Technical specifications

Dimensions	280 x 165 x 137 mm
Weight	2.0 kg
Fixation	Standard back plate with 2 magnets
Sensors (see sensor specifications)	4 gases, 1 high power socket
Visible alarm	Green LED for SAFE indication Red LED for ALARM indication Optional 107 dB beacon sounder (item no: AIR-BEAC-010)
System communication	Stand-alone via cable type 1 or 2, RS 485 or Wireless via 2.4 GHz ISM band, complies with the IEEE 802.15.4 standard and 3/4G with the WatchGas remote online platform
Range wireless	300 meters (with line of sight) (2.4 GHz)
Communication	Max. 50 remote detectors in one system
Keys and display	2 Magnet reed contact switches LCD text screen with 2 lines and background lighting
Sampling pump	Built-in pump
Energy supply	9 - 36V DC. Backup battery is basic included Battery run-on time max. 60 min.
Potential free contact	Three free programmable contacts rated Maximum 24V DC 2A
Operation temperature	-20°C to 45°C
Humidity	0 - 95% RH, non-condensing
Data logging	SD Card logging
IP-Rating	IP65

AIRWATCH PUMP SPECIFICATIONS

Operating flow	400 - 800 ml/min with adjustable upper and lower limit flow alarm
Free flow	1900 ml/min
Flow rate at 100/-100 mbar	920/850 ml/min
Max. pressure	400 mbar
Max. vacuum	-400 mbar
Max. Sampling hose	50m.

The pump of the AirWatch is capable of being used with a maximum hose length of 50 meters.

The AirWatch pump flow is monitored so that a flow is always present. If the filter gets blocked by water, excessive dust or for any other reason, it generates a pump alarm.

13. Limited Warranty

WATCHGAS warrants this product to be free of defects in workmanship and materials-under normal use and service-for two years from the date of purchase from the manufacturer or from the product's authorized reseller.

The manufacturer is not liable (under this warranty) if its testing and examination disclose that the alleged defect in the product does not exist or was caused by the purchaser's (or any third party's) misuse, neglect, or improper installation, testing, or calibrations. Any unauthorized attempt to repair or modify the product, or any other cause of damage beyond the range of the intended use, including damage by fire, lightning, water damage or other hazard, voids liability of the manufacturer.

In the event that a product should fail to perform up to manufacturer specifications during the applicable warranty period, please contact the product's authorized reseller or WATCHGAS service center at +31 (0)85 01 87 709 for repair/return information.



WatchGas B.V.
Klaverbaan 121
2908 KD Capelle aan den IJssel
The Netherlands
+31 (0)85 01 87 709
info@watchgas.eu - www.watchgas.eu

All rights reserved. No part of this publication may be reproduced, distributed, or transmitted in any form or by any means, including photocopying, recording, or other electronic or mechanical methods, without the prior written permission of the publisher, except in the case of brief quotations embodied in critical reviews and certain other noncommercial uses permitted by copyright law. For permission requests, contact WatchGas B.V.

V1.7
02-03-21