



USER MANUAL
STATIONARY
PHOTOIONIZATION
DETECTOR VOCPoint

we watch gas where you can't

EU-DECLARATION OF CONFORMITY

The manufacturer or the European Authorized Representative:

WatchGas B.V.
Klaverbaan 121
2908 KD Capelle a/d IJssel
The Netherlands

declares that the product:

Stationary Photoionization Detector VOCPoint-*

Artikelnummer / Part No.: 7162010-7162020-7162030, 7162040-7162050-7162060

based on the EC-Type Examination Certificate:

FTZU 24 ATEX 0044X
IECEX FTZU 24.0007X



II 2G Ex db IIC T6 Gb IP64 -40 °C ≤ Ta ≤ +60 °C

complies with ATEX Directive 2014/34/EU, Annex III. Quality Assurance Notification complying with Annex IV of the ATEX Directive 2014/34/EU has been issued by ExVeritas ApS Notified Body number: 2804.

ATEX: ExVeritas 24PQAN0374, IECEX: GB/EXV/QAR24.0001/00, EN80079-34:2018

Harmonized standards: EN IEC 60079-0:2018/AC:2020-02, EN 60079-1:2014/AC:2018-09

This product is in conformance with the EMC-Directive 2014/30/EU (electromagnetic compatibility):

Harmonized standards: EN 50270:2006, Type 2 (placing on the market before 2016-04-19)

Patrick Sieben

CEO WatchGas

23-07-2024

CONTENTS

1. GENERAL	4	7. MAINTENANCE AND SERVICE	30
2. SAFETY AND USAGE INSTRUCTIONS	4	7.1. Maintenance Intervals	31
2.1. Terms and Symbols	4	7.2. Safety Screws	31
2.2. Correct Use	4	7.3. How To – Open the Device	32
2.3. Liability Information	5	7.4. How To – Remove the PCU-PCB	33
2.4. Safety and Precautionary Measures to be adopted	5	7.5. How To – Replace the PID Lamp	34
2.5. Permanent Instrument Warranty	6	7.6. How To – Clean the PID Lamp	35
3. VOCPoint AT A GLANCE	7	7.7. How To – Replace the Filter Port – Filter Cartridge	35
4. INSTALLATION	7	7.8. How To – Replace the Sample Port – Dust Filter	36
4.1. Mechanical Installation	8	8. TECHNICAL DATA	37
4.2. Electrical Installation	9	9. APPROVALS	38
4.3. Filter Port – Installation	11	9.1. Marking, Certificates and Approvals According to the Directive 2014/34/EU (ATEX)	38
4.4. Sample Port – Installation	12	9.2. Marking and Certificates according to IECEx	40
5. USER INTERFACE	13	10. APPENDIX	42
5.1. Startup	13	10.1. Error Messages	42
5.2. Display Overview	13	10.2. Mechanical Drawing	43
5.3. Operating Buttons	13	11. CONTACT INFORMATION	44
5.4. Instrument Info	14	12. ORDERING INFORMATION	45
5.5. Instrument Menu	14	12.1. VOCPoint with 10,6eV lamp	
6. OPERATION	15	part number: 7162010-7162020-7162030	45
6.1. Calibration	15	12.2. VOCPoint with 11,8eV lamp	
6.1.1. Calibration Procedure	16	part number: 7162040-7162050-7162060	45
6.1.2. Calibration Test	18	13. SCOPE OF DELIVERY	46
6.2. Measurement Configuration	19	14. SPARE PARTS	47
6.2.1. Calibration Data	19	15. ACCESSORIES	49
6.2.2. Response Factor	20		
6.2.3. Alarm Setting	21		
6.2.4. Current Loop			
(4 ... 20 mA or 0 ... 5 mA)	21		
6.3. Purge Mode	22		
6.4. RS485 (MODBUS)	24		
6.5. Reset (Default Setting)	26		
6.6. Service Mode	27		
6.7. Diagnostic	27		
6.8. Measurement Ranges	28		
6.9. Resolution of Measurement Result	29		
6.10. Relays	29		
6.11. Output States	30		

1. GENERAL

The company WatchGas (hereinafter the 'manufacturer') provides with the Stationary Photoionization Detector VOCPoint (hereinafter the 'device') a continuously measuring detector for volatile organic compounds (VOCs) with a high stable hollow cathode lamp with Ceramic Discharge Channel with an ionization potential < 10.6 eV. The use of new technologies for the excitation source and the sensor allows a high stability of measurement and longer maintenance intervals. An integrated active carbon filter and the circuit sampling an automatic purging and automatic calibration are controlled.

2. SAFETY AND USAGE INSTRUCTIONS

2.1 TERMS AND SYMBOLS

In this manual, certain common terms and symbols used to warn you of dangers or to give you cautions that are important in avoiding injury or damage. Observe and follow these cautions and regulations to avoid accidents and damage. These terms and symbols explained below.

1. DANGER

Indicates a hazardous situation, which, if not avoided, WILL result in death or serious injury.

2. WARNING

Indicates a hazardous situation, which, if not avoided, COULD result in death of serious injury.

3. CAUTION

Indicates a hazardous situation, which, if not avoided, MAY in minor or moderate injury.

4. NOTICE

Indicates a property damage message.

5. Usage

Indicates a helpful information, hints or recommendation.

2.2. CORRECT USE

The device is suitable for outdoor and indoor applications without limitations, e.g. offshore industry, chemical and petrochemical industry, water and sewage industry. The device comes in a flameproof enclosure and is useable in explosive atmosphere.

It is imperative that this user manual be read and observed when using the product. In particular, the safety instructions, as well as the information for the use and operation of the product, must be carefully read and observed. Furthermore, the national regulations applicable in the user's country must be taken into account for a safe use.

WARNING



This product is supporting life and health. Inappropriate use, maintenance or servicing may affect the function of the device and thereby seriously compromise the user's life.

Before use, the product operability must be verified. The product must not be used if the function test is unsuccessful, it is damaged, a competent servicing/maintenance has not been made, genuine manufacturer spare parts have not been used.

Alternative use, or use outside this specification will be considered as non-compliance. This also applies especially to unauthorised alterations to the product and to commissioning work that has not been carried out by manufacturer or authorised persons.

2.3. LIABILITY INFORMATION

The manufacturer accepts no liability in cases where the product has been used inappropriately or not as intended. The selection and use of the product are the exclusive responsibility of the individual operator. Product liability claims, warranties also as guarantees made by manufacturer with respect to the product are voided, if it is not used, serviced or maintained in accordance with the instructions in this manual.

2.4. SAFETY AND PRECAUTIONARY MEASURES TO BE ADOPTED

WARNING



The following safety instructions must be observed implicitly. Only in this way can the safety and health of the individual operators, and the correct functioning of the instrument, be guaranteed.

- The device described in this manual must be installed, operated and maintained in strict accordance with their labels, cautions, instructions, and within the limitations stated.
- The device is designed to detect volatile organic compounds or vapours in air.
- Do not mount the device in direct sunlight as this could cause overheating of the sensor.
- The device must be installed vertical with the filter port unit downward to avoid plugging of the gas inlets by particles or liquids.
- The only absolute method to ensure proper overall operation of the device is to check it with a known concentration of the gas for which it has been calibrated. Consequently, calibration checks must be included as part of the routine inspection of the system.
- As with all devices of these types, high levels of, or long exposure to, certain compounds in the tested atmosphere could contaminate the sensor. In atmospheres where the device may be exposed to such materials, calibration must be performed frequently to ensure that the operation is dependable and display indications are accurate.
- Use only genuine manufacturer replacement parts when performing any maintenance procedures provided in this manual. Failure to do so may seriously impair instrument performance. Repair or alteration of the device, beyond the scope of these maintenance instructions or by anyone other than an authorised manufacturer service personnel, could cause the product to fail to perform as designed.
- The device is designed for applications in hazardous areas under atmospheric conditions.
- Significant dust deposits on the gas inlets will increase the response time of the device. Checks for dust deposits must be done at regular intervals.

2.5. PERMANENT INSTRUMENT WARRANTY

WARRANTY

Seller warrants that this product is designed and manufactured to the latest internationally recognized standards by manufacturer under a quality management system that is certified to ISO 9001. As such the manufacturer warrants that this product will be free from defective parts and workmanship and will repair or (at its option) replace any instruments which are or may become defective under proper use within twenty four [24] months from date of commissioning by an approved manufacturer representative. This warranty does not cover wearing parts, i.e. parts inside the gas way like valves, pumps, lamp and other or damage caused by accident, abuse or abnormal operating conditions.

Defective goods must be returned to manufacturer premises accompanied by a detailed description of any issue. Where return of goods is not practicable manufacturer reserves the right to charge for any site attendance where any fault is not found with the equipment. Manufacturer shall not be liable for any loss or damage whatsoever or howsoever occasioned which may be a direct or indirect result of the use or operation of the Contract Goods by the Buyer or any Party.

This warranty covers instrument and parts sold to the buyer only by authorized distributors, dealers and representatives as appointed by manufacturer. The warranties set out in this clause are not pro rata, i.e. the initial warranty period is not extended by virtue of any works carried out there under.

In no event will manufacturer be liable for any incidental damages, consequential damages, special damages, punitive damages, statutory damages, indirect damages, loss of profits, loss of revenues, or loss of use, even if informed of the possibility of such damages. Manufacturer is liability for any claims arising out of or related to this product will in no case exceed the order value. To the extent permitted by applicable law, these limitations and exclusions will apply regardless of whether liability arises from breach of contract, warranty, tort (including but not limited to negligence), by operation of law, or otherwise.

3. VOCPoint AT A GLANCE

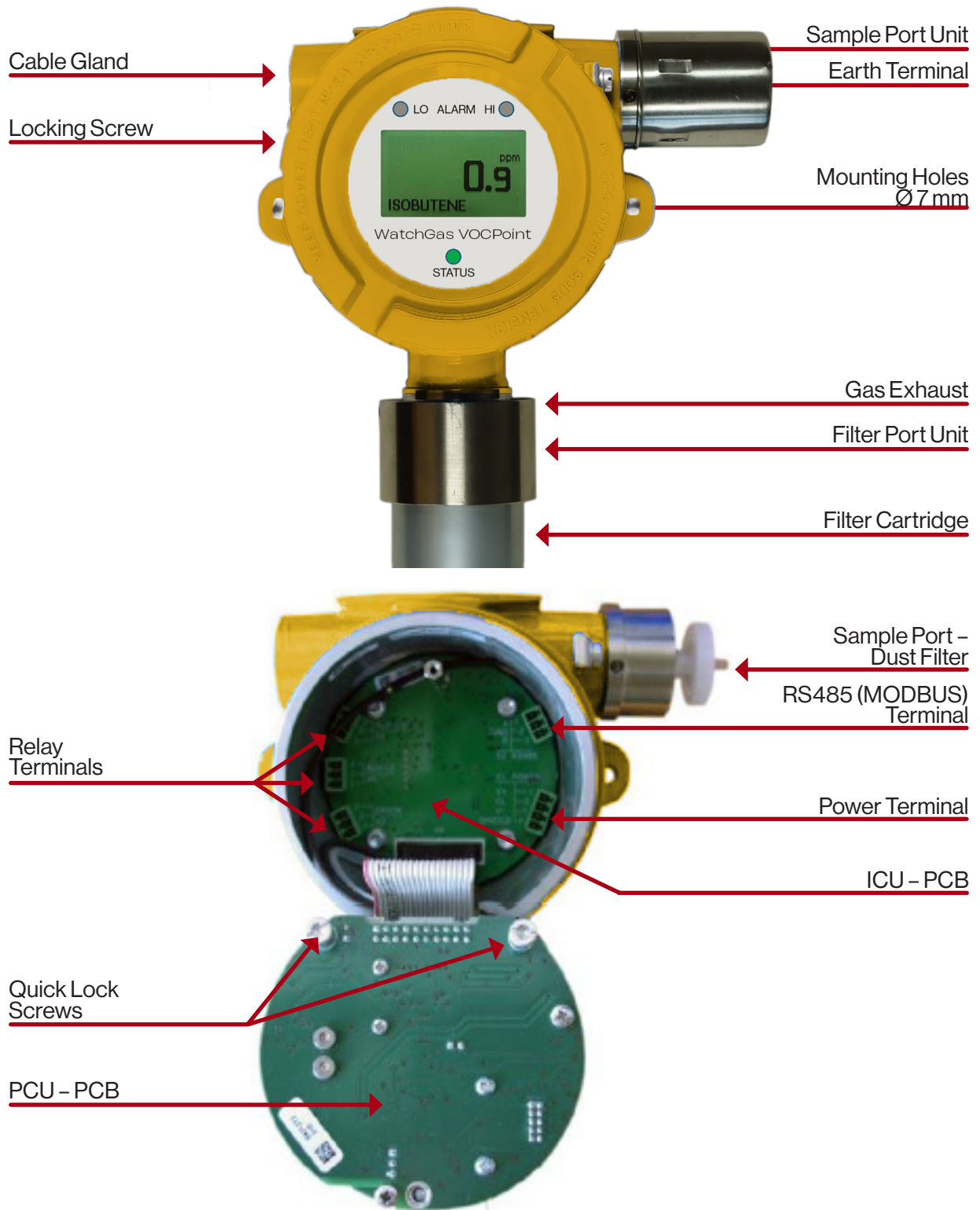

4. INSTALLATION



WARNING

The device contains high voltage parts inside. Disconnect the power supply before maintenance and service.

The device should be installed where gas leaks are expected. The installation position depends on the gas density, either in the upper area of the room under the ceiling for gases lighter than air or close to the ground for gases heavier than air. Also, consider how air movement may affect the ability of the device to detect gas. The display on the front of the instrument must always be clearly visible; the view must not be obstructed.



Before beginning the installation, check that the delivered components are complete and correct referring to the shipping documents and the sticker on the shipment carton.



When preparing the assembly, make sure that the mounting arrangement is correct for the particular device.

4.1. MECHANICAL INSTALLATION



How To – Attaching to the Wall

1. Using the device fixing holes (Ø 7 mm) as a template, mark the holes for the two fixing screws.
2. Drill two holes of appropriate diameter.
3. Attach the device to the wall, vertical with the filter port unit downward, using 6 mm diameter screws with an appropriated length, at the place of installation.



The device must be installed vertical with the filter port unit downward to avoid plugging of the gas inlets by particles or liquids.

4.2. ELECTRICAL INSTALLATION

WARNING



The device must be installed only in compliance with the applicable regulations, otherwise the safe operation of the instrument is not guaranteed.

- Shielded cable for measuring devices is recommended.
- All cable shields to be terminated to ground earth at one end only.
- ATEX and/or IECEx cable glands Ex d IIC certified must be mandatory installed.
- Water or impurities can penetrate the instrument through the cable. In hazardous areas, it is recommended to install the cable in a loop just before entry into the instrument or to slightly bend it to prevent water from entering.



NOTICE

The power supply is defined as 24 VDC.

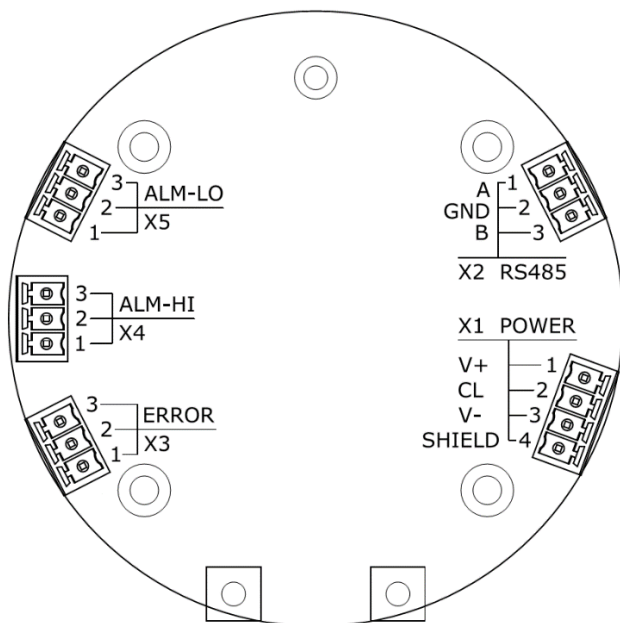

How To – Install Electrical Connection

1. Open the device. (See chapter 7.3.)
2. Unscrew clamping nut at the cable gland.
3. Put clamping nut on the cable.
4. Insert cable for connection into the device.
5. Connect cable to the corresponding pin numbers of the terminal.
6. Tighten cable gland clamping nut, check that cable cannot move within the cable gland.
7. Replace electronic unit and secure the captive screw.
8. Replace enclosure lid and secure the locking screw.

X1 Power

- | | | | |
|---|--------|-------------|-------------------------|
| 1 | V+ | 24 VDC | [Positive Supply] |
| 2 | CL | 4 ... 20 mA | [Current Loop Output] |
| 3 | V- | 0 VDC | [Negative Supply] |
| 4 | SHIELD | | [Ground Earth] |

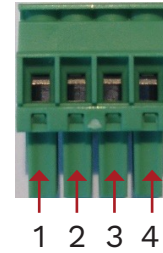

X2 RS485 (MODBUS)

- | | | | |
|---|-----|--|----------------------------|
| 1 | A | | [Non Inverting Terminal] |
| 2 | GND | | [Isolated Ground] |
| 3 | B | | [Inverting Terminal] |



X3 ERROR

- | | | | |
|---|-----------|--|--|
| 1 | Relay NC | | [Normally Closed De-Energized Contact] |
| 2 | Relay COM | | [Common Contact] |
| 3 | Relay NO | | [Normally Open De-Energized Contact] |



X4 ALARM HIGH

- | | | |
|-----------|--|--|
| Relay NC | | [Normally Closed De-Energized Contact] |
| Relay COM | | [Common Contact] |
| Relay NO | | [Normally Open De-Energized Contact] |



X5 ALARM LOW

- | | | |
|-----------|--|--|
| Relay NC | | [Normally Closed De-Energized Contact] |
| Relay COM | | [Common Contact] |
| Relay NO | | [Normally Open De-Energized Contact] |



The terminal plugs accepts AWG 26 (0.14 mm²) to AWG 16 (1.5 mm²) wire.

4.3. FILTER PORT – INSTALLATION

CAUTION

Do not use the device without filter cartridge, dust filter and protection cap. Impurities within ambient air can get into gas path and destroy the sensor.

FILTER PORT – FILTER CARTRIDGE

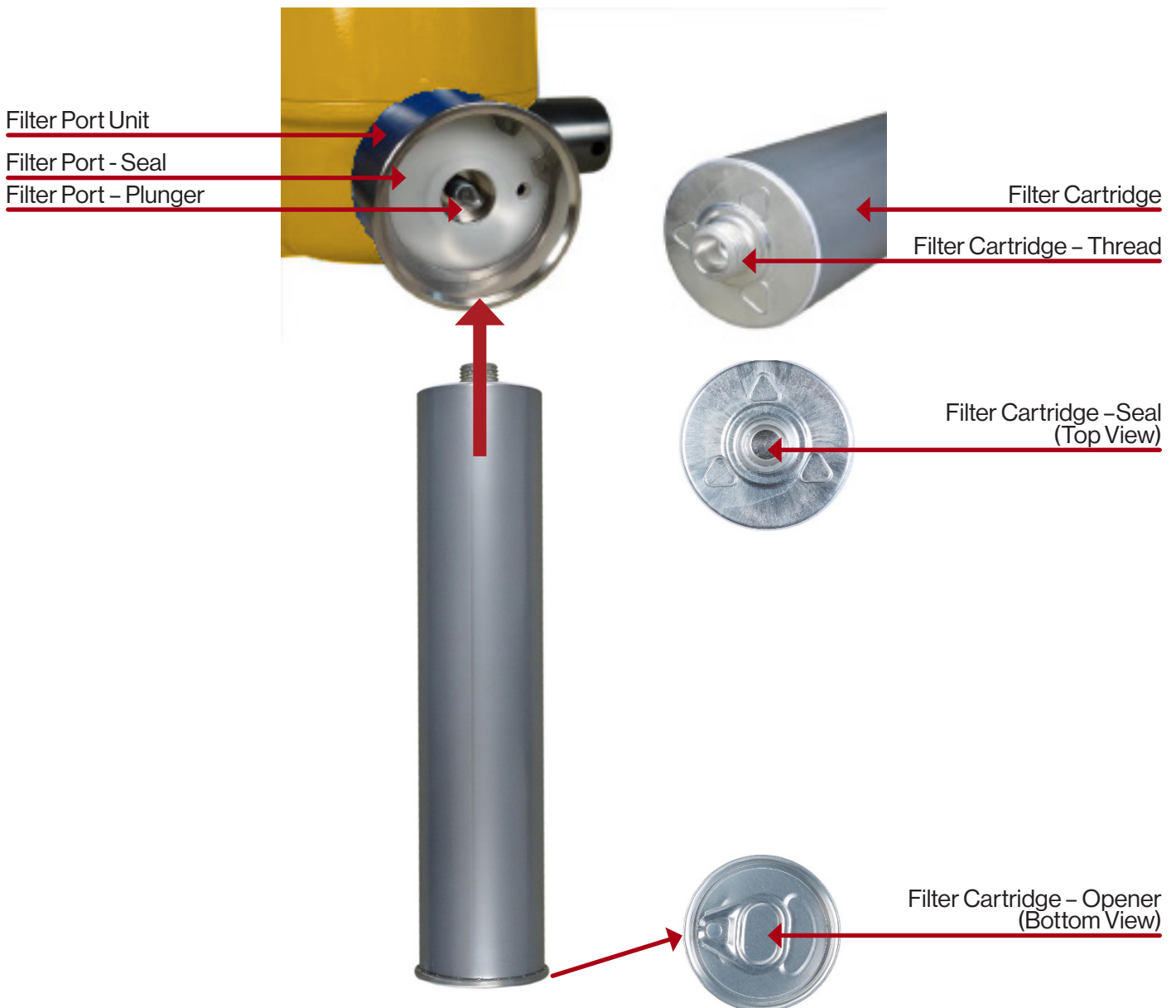

How To – Install the Filter Port – Filter Cartridge

1. Check that the filter port – seal is fitted and not damaged.
2. Check that the filter cartridge – seal is not broken.
3. Screw the filter cartridge into the filter port unit. Only light force is required.
4. Open the filter cartridge after installation by using the opener.



Calibrate the device after installation of a new filter cartridge.

4.4. SAMPLE PORT – INSTALLATION

CAUTION

Do not use the device without filter cartridge, dust filter and protection cap. Impurities within ambient air can get into gas path and destroy the sensor.

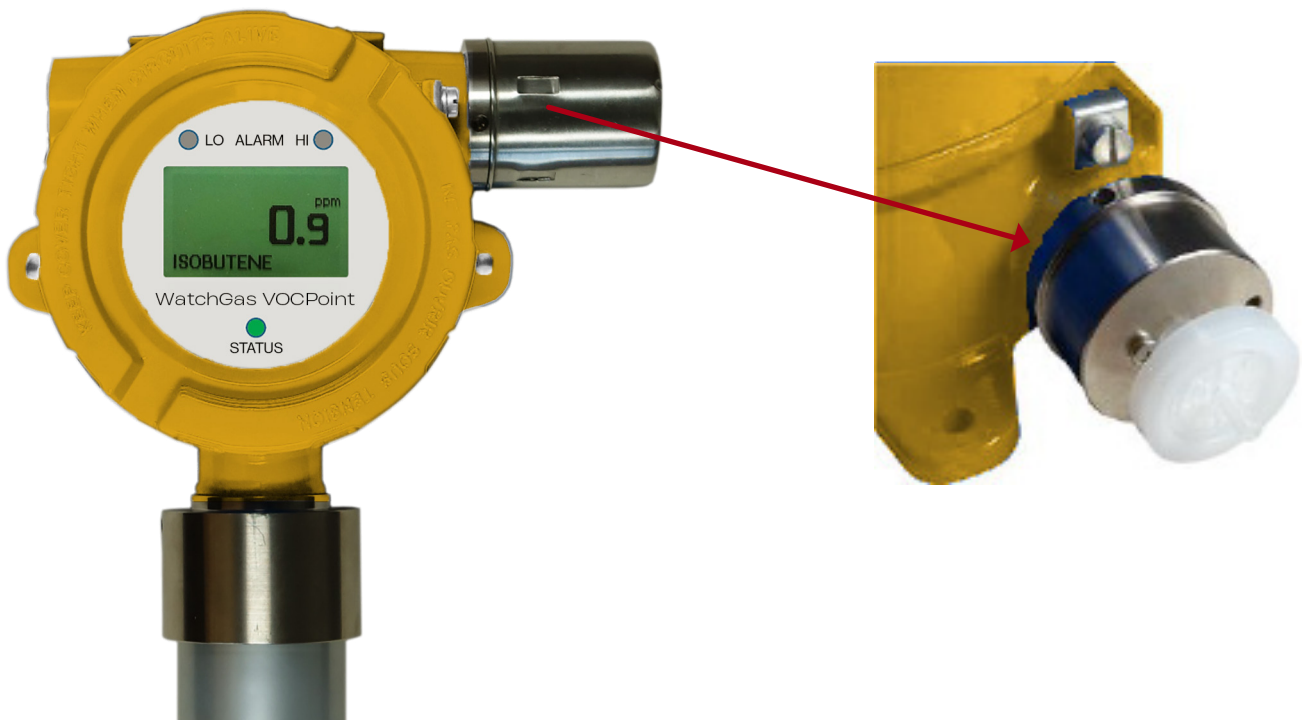

How To – Install the Sample Port – Dust Filter

1. Remove the sample port – protection cap by pulling sideward.
2. Check that the sample port – dust filter is assembled and free of impurities.
3. Replace sample port – protection cap with gas intake hole downward.



Calibrate the device after installation of a new dust filter.

5. USER INTERFACE

5.1. STARTUP

After the power supply voltage has been applied, the device is automatically switched on and carries out a warm up and self-diagnostic sequence, which takes approximately 30 seconds. During this period, the current loop output is set to startup state (see chapter 6.11). If the self-diagnostic sequence is satisfactorily completed, the main screen is displayed and the current loop output moves to a value representing the measurement value.

5.2. DISPLAY OVERVIEW

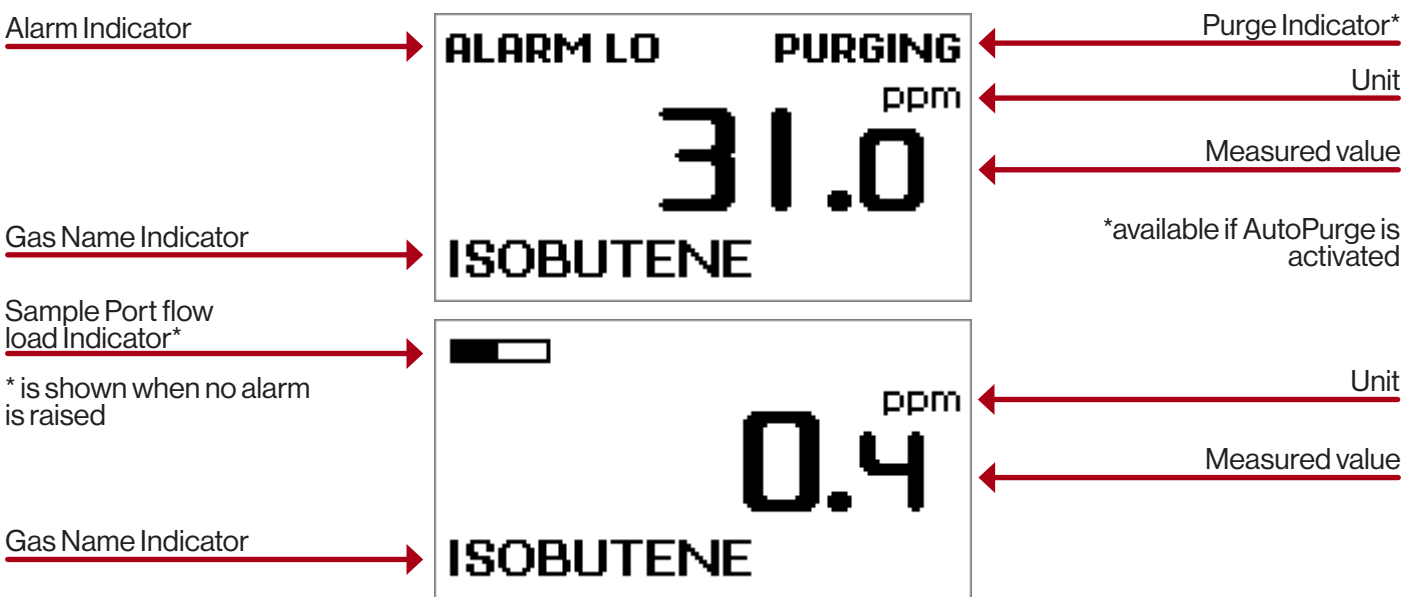

Sample Port - Dust Filter should be replaced when Sample Port flow load Indicator is filled up completely.

5.3. OPERATING BUTTONS

The device is operated using three magnetic field sensitive buttons, which are placed (left, middle, right) at the bottom line under the display. An appropriate magnetic pen is supplied with the device.

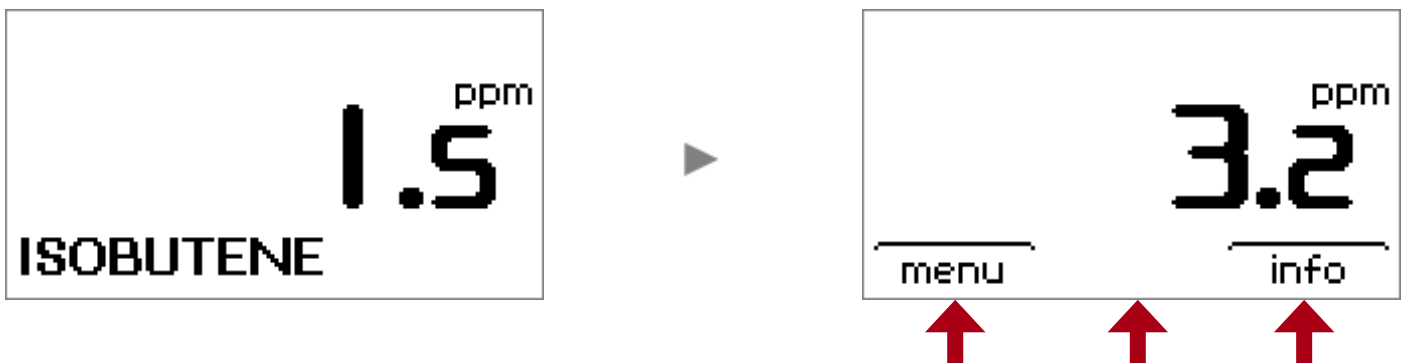

How To – Activate a Button

1. Place the magnetic pen directly above the display on the corresponding area.
2. The display will respond to user input and shows the navigation bar.
3. Select the desired menu item.



After a period of 120 seconds of inactivity, the navigation bar disappears automatically.

5.4. INSTRUMENT INFO



This feature allows inspecting the instruments settings WITHOUT leaving the measurement function.

How To – Activate the Instrument Info

1. Select the item “info” at the navigation bar.
2. Select the item “next” repeatedly will scroll through the info screens.

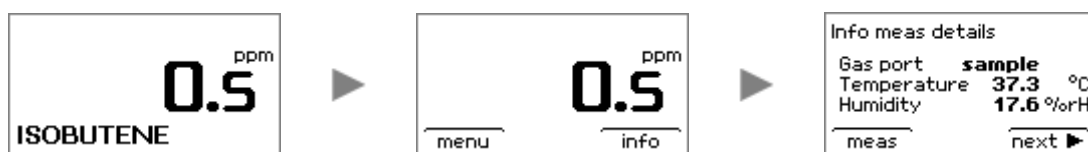

5.5. INSTRUMENT MENU



The instrument menu is protected by a four-digit password and should only be changed by qualified and authorised persons. The default password is set to 0000.

WARNING



When entering the instrument menu the measurement function will ABORT. No measurement will be performed, all alarms will be switched off, the current loop, the relays and the LEDs will be set to maintenance state (see chapter 0). Therefore, access to menu is protected by password and you will be prompted twice before entering the menu. The password can be changed only via PC remote connection.

How To – Activate the Instrument Menu

1. Select the item “menu” at the navigation bar
2. Enter the required password and confirm the process with “accept”
3. Confirm access to the instrument menu

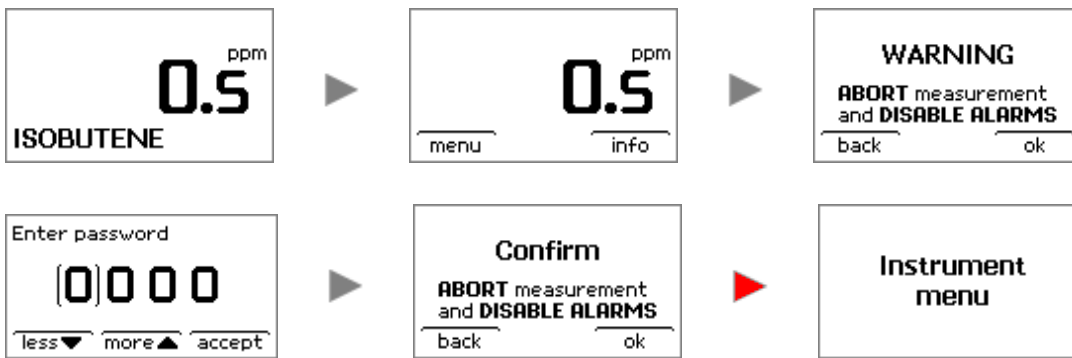

6. OPERATION

6.1. CALIBRATION



WARNING

Test gases used for calibration can be a health risk. Proper ventilation or extraction has to be ensured.

GENERAL

The calibration must be done at regular intervals in accordance with applicable national and regional regulations. The device calibration and the accuracy of the measuring can easily be checked at any time by using the build-in **Calibration Test** function. The device must be calibrated after installation.



Connect power supply to the device at least one hour before attempting a calibration.

PREPARATIONS BEFORE CALIBRATION / CALIBRATION TEST

To perform a calibration, you need a pressure cylinder of SPAN Gas and / or ZERO Gas, a flow reducer, a tube and a T-piece. The flow reducer should provide a flow of at least 500 ml/min. The T-piece should be installed between flow reducer and sample port – dust filter. The open tube length on T-piece junction should be 300 – 500 mm. (see following connection scheme)





For calibration, it is recommended to use the **Calibration Kit** from accessories. (see chapter 15 Accessories)

6.1.1. CALIBRATION PROCEDURE

CALIBRATION METHODS

The device supports two different methods for calibration. (**Standard Calibration** with SPAN Gas [Isobutene/ isobutylene in air] and **Extended Calibration** with SPAN Gas [User gas in air] with known concentration) Which calibration method is carried out, depends on the measurement task, e.g. overview measurements, workplace monitoring, control measurements, worst-case measurements, environmental measurements and emission measurements.



Both calibration data for **Extended Calibration** and **Standard Calibration** are stored independently of one another. Via the Instrument Menu >> MEAS CONFIG, the user can choose most appropriate calibration data setting for his measurement application.

Both calibration methods using a two-point-calibration, which can be performed as a manual or an automatic calibration.

MANUAL CALIBRATION MODE

- Both, fresh air (ZERO Gas) and calibration gas (SPAN Gas) must be applied successively to the Sample Port – Gas Input.
- The user will be asked for applying the right gas during the calibration sequence.

AUTOMATIC CALIBRATION MODE

- Only, calibration gas (SPAN Gas) must be applied to the Sample Port – Gas Input.
- Fresh air (ZERO Gas) will be taken automatically from the Filter Port – Cartridge.
- The device selects the gas input automatically during the calibration sequence.



After starting any calibration, calibration gas [ZERO or SPAN Gas] must be applied until calibration step is finished. The calibration procedure can be cancelled at any time by pressing “abort”. The previous device calibration will be used.

How To – Start Calibration

1. Go to the Instrument Menu and select CALIBRATION
2. Select “run” to go to calibration screen and select START (Start new calibration)
3. Press “accept” to start new calibration and follow the instructions on the screen

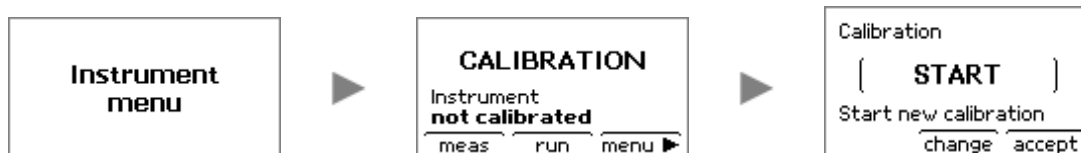

PREPARATIONS BEFORE CALIBRATION / CALIBRATION TEST

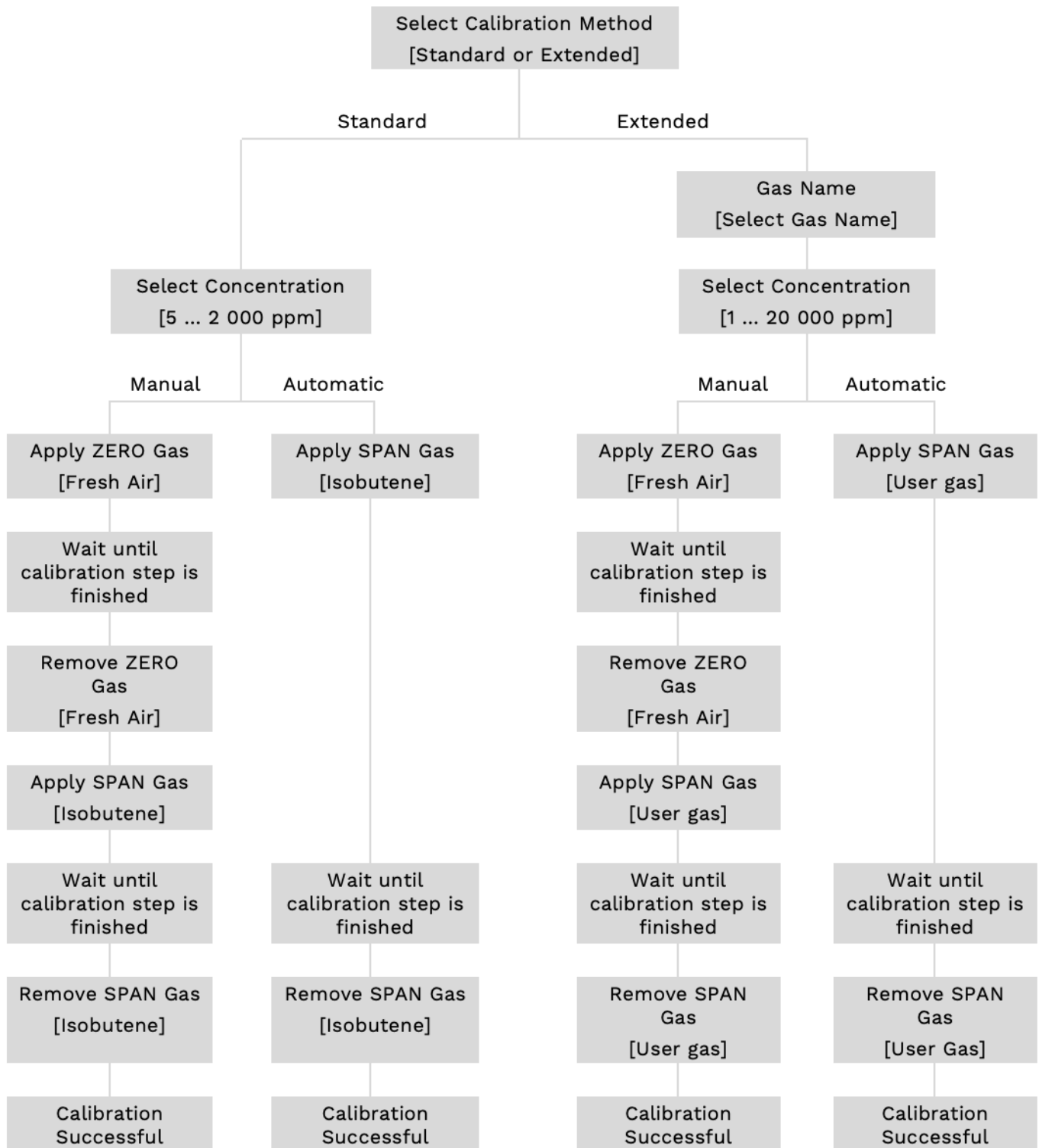

6.1.2. CALIBRATION TEST

The calibration test verifies both:

- SPAN Gas calibration [SAMPLE PORT]
- ZERO Gas calibration [FILTER PORT¹ or SAMPLE PORT²]

NOTE 1: If Automatic Calibration Mode was used.

NOTE 2: If Manual Calibration Mode was used.

How To – Start Calibration Test

1. Go to the Instrument Menu and select CALIBRATION
2. Select “run” to go to calibration screen
3. Select TEST and press “accept”
4. Select SAMPLE PORT or FILTER PORT and press “run”

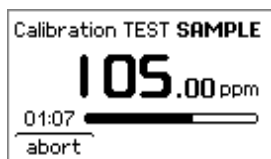
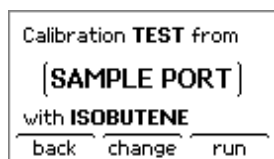
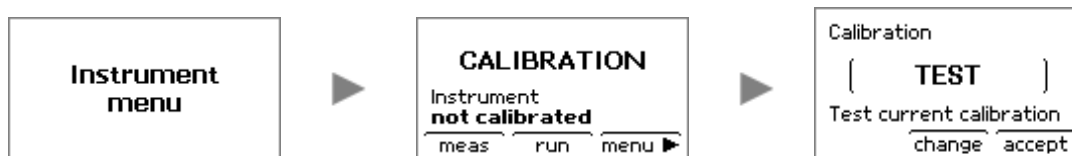

Calibration TEST from SAMPLE PORT

- Apply SPAN Gas to the Sample Port
- The current measurement value will be displayed for 3 minutes

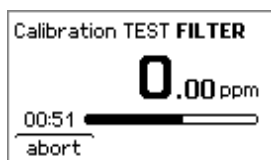
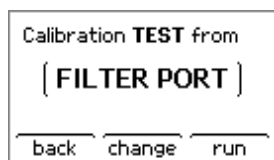

Calibration TEST from FILTER PORT

- The device takes ambient air through the Filter Port
- The current measurement value will be displayed for 2 minutes

6.2. MEASUREMENT CONFIGURATION

This menu will be used for device settings.

How To – Configure Measurement

1. Go to the Instrument Menu and select MEAS CONFIG
2. Select “run” to start measurement configuration



Calibration	▶	<p>This menu item allows you to select which calibration data will be used for the measurement.</p> <p>The user can select between the following two calibration data settings:</p> <ul style="list-style-type: none"> • STANDARD or EXTENDED 	<p>See section: 6.2.1 Calibration Data</p>
Response	▶	<p>This menu item allows you to select a response factor.</p> <ul style="list-style-type: none"> • ISOBUTENE (ISOBUTYLENE), BENZENE, Custom, ... 	<p>See section: 6.2.2 Response Factor</p>
Alarms	▶	<p>This menu item allows you to select two user configurable alarm levels.</p> <ul style="list-style-type: none"> • ALARM LO and ALARM HI 	<p>See section: 6.2.3 Alarm Setting</p>
Current Loop	▶	<p>This menu item allows you to configure Current Loop.</p> <ul style="list-style-type: none"> • OUTPUT and SIGNAL 	<p>See section: 6.2.4 Current Loop (4 ... 20 mA or 0 ... 5 mA)</p>

6.2.1. CALIBRATION DATA

The device supports two different methods for calibration. (**Standard Calibration** with SPAN Gas [Isobutene/isobutylene in air] and **Extended Calibration** with SPAN Gas [User gas in air] with known concentration)

This menu setting allows you to select which type of calibration data are used for measurement.



Both calibration data for **Extended Calibration** and **Standard Calibration** are stored independently of one another.

How To – Select Calibration Data

1. Go to the Instrument Menu and select MEAS CONFIG
2. Select “run” to start measurement configuration
3. Select Calibration, “change” calibration data setting and “accept”
4. Select SAMPLE PORT or FILTER PORT and press “run”

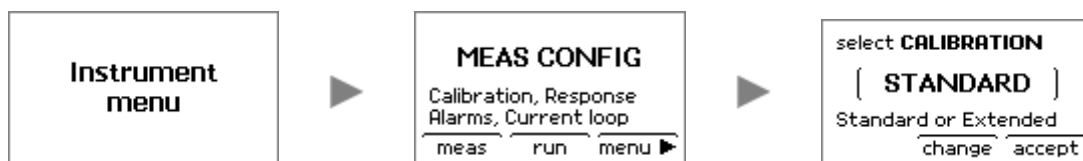

6.2.2. RESPONSE FACTOR

Based on SPAN Gas [Isobutene/ isobutylene] calibration for correct reading of other VOCs it is necessary to set a response factor. This factor reflects the sensitivity of the known VOC compared with the calibration gas and can be more or less than 1. A list of predefined response factors based on official literature and custom factors are stored in the device and can be selected by user. Additionally the user got the possibility to specify a list of up to 100 particular response factors by an additional configuration software via PC (optional communication cable required). After selecting a response factor, the gas name will be shown on the display.

LIST OF RESPONSE FACTORS FOR PID WITH 10.6 EV LAMP:

LIST ITEM	GAS NAME	RESPONSE FACTOR
1	ISOBUTENE (ISOBUTYLENE)	1.00
2	BENZENE	0.55
3	Custom	0.50
.		.
10	Custom	5.00



The list of response factors are only available if **Standard Calibration** is selected.

How To – Select Response Factor

1. Go to the Instrument Menu and select MEAS CONFIG
2. Select “run” to start measurement configuration
3. Select Calibration, choose STANDARD and “accept”
4. Select Response and modify response setting

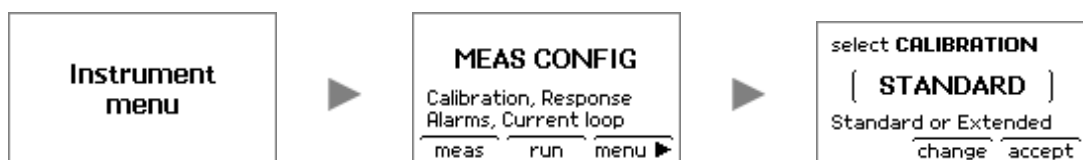

RESPONSE SCREEN



6.2.3. ALARM SETTING



It is obligated to set “ALARM HI” higher than “ALARM LO”.

The device features two user configurable alarm levels:

- ALARM LO 0.1 – 20 000 ppm
- ALARM HI 0.2 – 20 000 ppm

How To – Configure Alarm Setting

1. Go to the Instrument Menu and select MEAS CONFIG
2. Select “run” to start measurement configuration
3. Select Alarm LO level and change parameter
4. Select Alarm HI level and change parameter

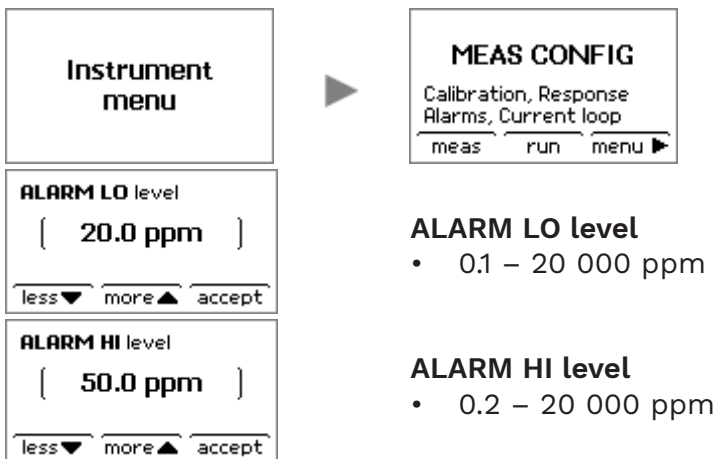

* alarm points below 5 ppm or low boiling point vapors, please consult factory

6.2.4. CURRENT LOOP (4 ... 20 MA OR 0 ... 5 MA)

The device is equipped with an analog current loop output, which converts the physical measurement result into an electrical signal. The device provides a 3-wire current loop output, which operates over the entire supply voltage range. The most common resistor in a 4 ... 20 mA loop is 250 ohm; however, depending on applied supply voltage the maximum load resistance must be considered.

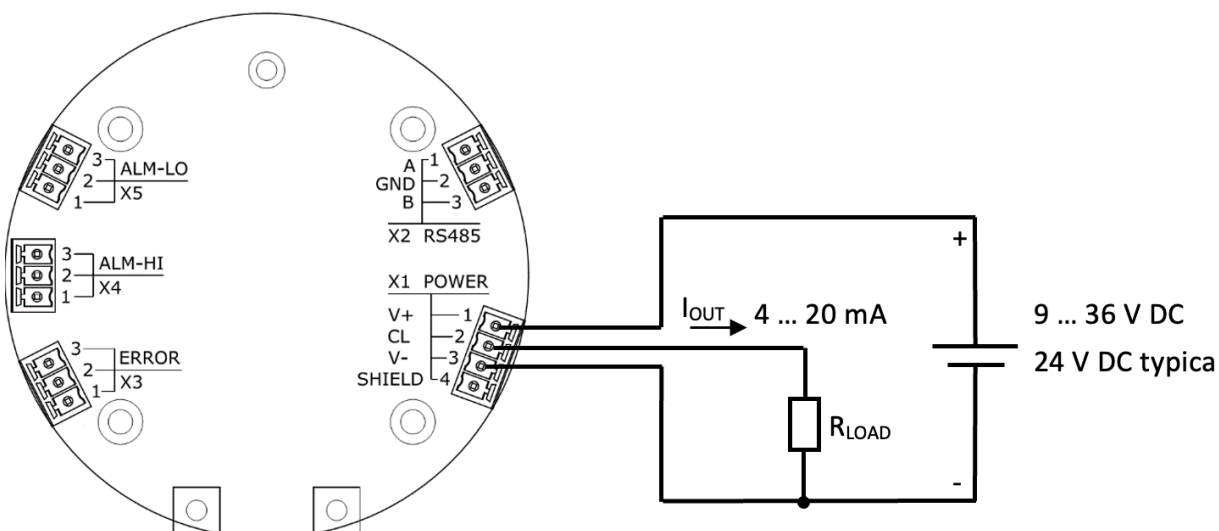

SUPPLY VOLTAGE	MAXIMUM LOAD RESISTANCE (R_{LOAD})
+9 V DC	330 Ohm
+24 V DC	1 000 Ohm
+36 V DC	1 500 Ohm

The output current (4 ... 20 mA or 0 ... 5 mA) and the corresponding signal range (0 ... 20 000 ppm) can be selected.

	EXAMPLE 1	EXAMPLE 2	EXAMPLE 3
Measurement result	80 ppm	80 ppm	12 ppm
Output range	4 ... 20 mA	4 ... 20 mA	0 ... 5 mA
Signal range	0 ... 100 ppm	0 ... 1000 ppm	0 ... 50 ppm
Output current	16.8 mA	5.28 mA	1.2 mA

How To – Configure Current Loop (4 ... 20 mA or 0 ... 5 mA)

1. Go to the Instrument Menu and select MEAS CONFIG
2. Select “run” to start measurement configuration
3. Select Current Loop OUTPUT to change output range
4. Select Current Loop SIGNAL to change signal range

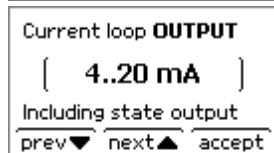
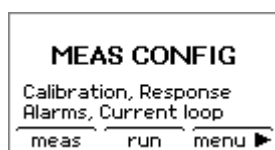

Select Current Loop OUTPUT

- 4 ... 20 mA; 0 ... 5 mA

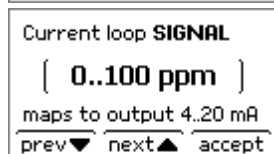

Select Current Loop SIGNAL

- 0 ... 10 ppm; 0 ... 50 ppm; 0 ... 100 ppm; 0 ... 200 ppm;
 0 ... 500 ppm; 0 ... 1 000 ppm; 0 ... 2 000 ppm;
 0 ... 5 000 ppm; 0 ... 10 000 ppm; 0 ... 20 000 ppm

6.3. PURGE MODE

Under most environmental conditions, a pollution of the PID sensor can decrease the measurement performance. Parts that are exposed to the sample gas like tubes, pump, valve, PID sensor and lamp window surface can be polluted on its surface. This may lead to incorrect measuring values over time. To provide the possibility of working under such hard conditions a purge mode is installed. The principle of this mode is a periodic interchange between ambient air, which is filtered by the active carbon filter and sample gas. The switching can be performed automatically by self-chosen time intervals or by one time manual user input.

The **Automatic Purge** mode is the default-operating mode for long-term measurements. Therefore, two time intervals must be configured:

PURGE TIME

- This parameter determines the purge time how long the device will be taken ambient air, filtered by an active carbon filter. During this time, the last valid measurement value is retained on the display. The purge time includes a recovery time fixed to 10 seconds at the end of each cycle.

MEAS TIME

- This parameter determines the measurement time how long the device will be taken sample gas from the sample port. During this time, the measurement value is continuously updated and shown on the display.

Auto purge timing

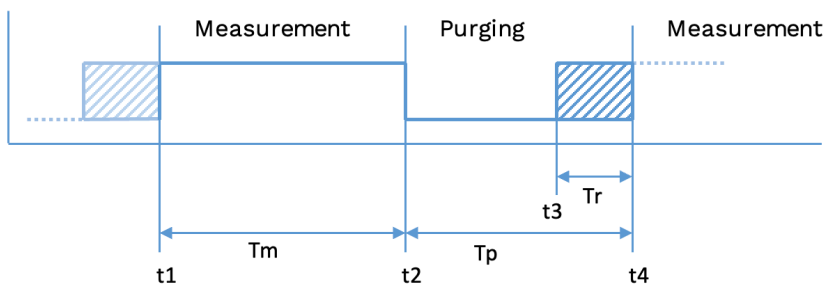

- Tm MEAS TIME
- Tp PURGE TIME (including recovery time (Tr))
- Tr Recovery time (fixed to 10 seconds)

t1	Begin of measurement cycle. The final measurement result is show at display.
t2	Begin of purge cycle. The valve is switched to filter input. The display shows the last measurement result.
t3	Begin of recovery cycle. The valve is switched to sample input. The display shows the last measurement result.
t4	Begin of next measurement cycle. The final measurement result is show at display.

How To – Setup Automatic Purge

- Go to the Instrument Menu and select Purge
- Select “run” to start configuration
- Select “AUTOMATIC”
- Configure **Automatic Purge** mode by PURGE TIME and MEAS TIME

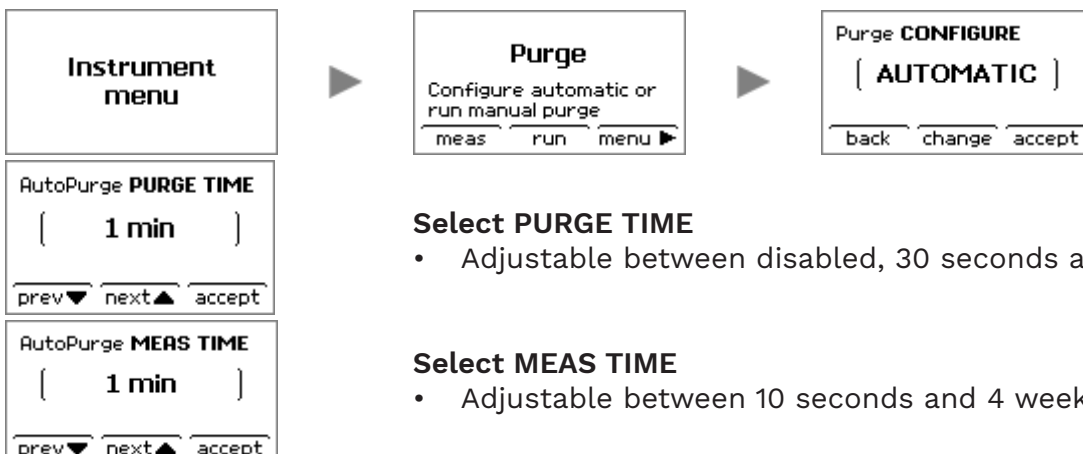



The **Automatic Purge** mode is made by default but can be **switched off**.

The **Manual Purge** mode can be selected at any time while the device is running.

How To – Setup Manual Purge

1. Go to the Instrument Menu and select Purge
2. Select “run” to start configuration
3. Select “MANUAL”
4. Select PURGE TIME and press “run” to start purging

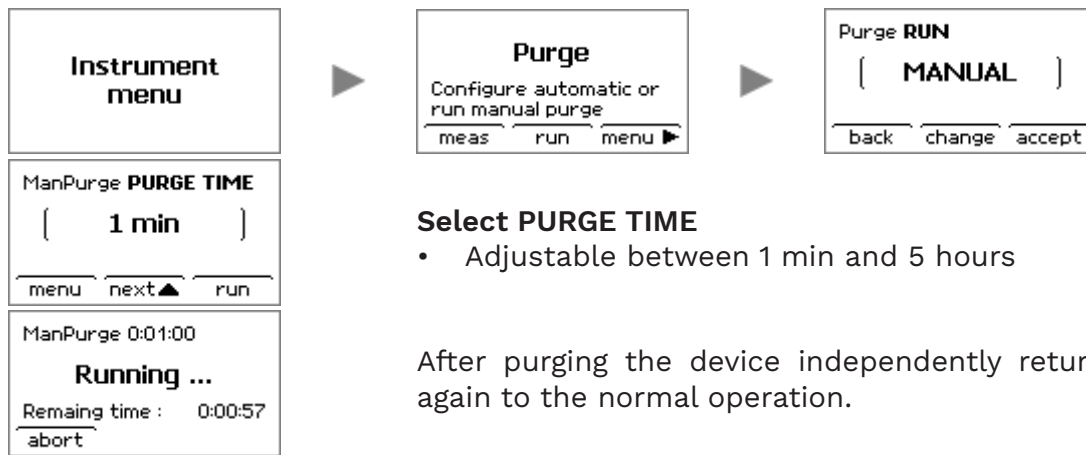

Select PURGE TIME

- Adjustable between 1 min and 5 hours

After purging the device independently returns again to the normal operation.

6.4. RS485 (MODBUS)

The device provides a RS485 (MODBUS) interface. This bus makes it possible to connect up to 32 devices including the host system to one line. For proper operation of the bus system, the first and the last device in chain must be terminated. The MODBUS protocol implementation provides ASCII and RTU modus and can be configured in the instrument menu.

How To – Configure RS485 (MODBUS)

1. Go to the Instrument Menu and select MODBUS
2. Select “change” to configure RS485 (MODBUS) interface

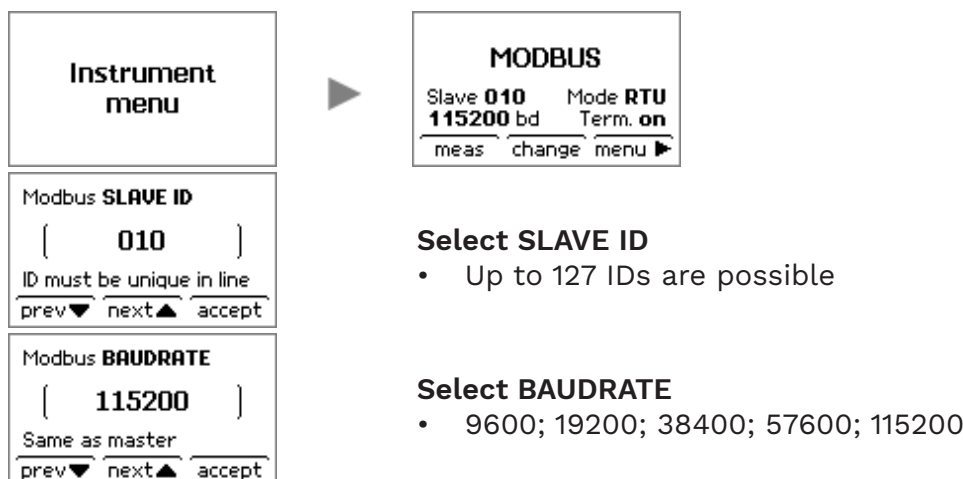

Select SLAVE ID

- Up to 127 IDs are possible

Select BAUDRATE

- 9600; 19200; 38400; 57600; 115200

Modbus MODE
(RTU)
Same as master
change accept

Select MODE

- Select ASCII or RTU Mode

Modbus TERMINATION
(ON)
Must be on if last in line
change accept

Select TERMINATION

- Select build in line termination resistor (120 Ohm)

Default Settings:

- Slave ID: 010
- Baud rate: 115200
- Mode: RTU
- Termination: Enable
- Parity: Even (fixed)

MODBUS REGISTER MAP

Register 3xxxx – Access via function code 0x04 (read only)

INSTRUMENT IDENTIFICATION

REGISTER NO	FORMAT	ACCESS	LENGTH	DESCRIPTION
30001	String	Ro	32 byte	Device identification
30017	String	Ro	32 byte	Device name
30033	String	Ro	32 byte	Device serial number

MEASUREMENT RESULTS

REGISTER NO	FORMAT	ACCESS	LENGTH	DESCRIPTION
30100	Float	Ro	4 byte	Measurement result [ppm]
30102	Float	Ro	4 byte	Temperature [°C]
30104	Float	Ro	4 byte	Humidity [%rH]
30106	UInt32	Ro	4 byte	Status information*
30108	Float	Ro	4 byte	Response factor
30110	Float	Ro	4 byte	Alarm LO level [ppm]
30112	Float	Ro	4 byte	Alarm HI level [ppm]

*see Status Information Bit Definition

BIT	DESCRIPTION
D00	1 = Alarm LO detected
D01	1 = Alarm HI detected
D02	reserved (0)
D03	1 = Over range detected
D04	1 = Under range detected
D05	1 = Filter dirty detected
D06	reserved (0)
D07	reserved (0)
D08	1 = Device is in initialization mode
D09	1 = Device is in measure mode
D10	1 = Device is in maintenance mode
D11	1 = Device is in idle mode
D12	1 = Extended calibration in use
D13	1 = Device is in purging
D14	reserved (0)
D15	1 = Summary error (D16 D31)

BIT	DESCRIPTION
D16	reserved (0)
D17	1 = Error flow detector
D18	1 = Error low flow
D19	1 = Error device initialization
D20	1 = Error Led control
D21	1 = Error current loop
D22	1 = Error PCU-PCB
D23	1 = Error ICU-PCB
D24	1 = Error Pid ADC
D25	1 = Error Pid humidity sensor
D26	1 = Error Valve
D27	1 = Error Relays
D28	1 = Error Pump not working
D29	1 = Error Pump blocked
D30	1 = Error Pid Lamp
D31	1 = Error Unknown

6.5. RESET (DEFAULT SETTING)



You have to calibrate the instrument after executing this function.

The device can be restored to the original factory defaults.

Alarm levels	ALARM LO	20 % of measurement range
	ALARM HI	50 % of measurement range
Calibration	Standard Calibration	
Current Loop	Output	4 ... 20mA
	Signal	0 ... 20 ppm (Low range)
		0 ... 100 ppm (Standard range)
		0 ... 2 000 ppm (High range)
Modbus	Slave ID	10
	Mode	RTU
	Baud rate	115200
	Parity	even
	Termination	Enable
AutoPurge	Meas Time	1 min
	Purge Time	1 min
Password	Set to default	0000
Response Factor	ISOBUTENE (ISOBUTYLENE)	x 1.00

How To – Reset to factory defaults

1. Go to the Instrument Menu and select RESET.
2. Select “run” resets the configuration to factory defaults.



Customized response factors that are generated via PC software VOCPoint Control Center will be deleted after reset.

6.6. SERVICE MODE

The service mode allows connecting the instrument to a PC via RS485 interface for advanced configuration.



PC software VOCPoint Control Center must be installed before you can connect the device to the PC. A special adaptor is required.

How To – Activate Service Mode

1. Go to the Instrument Menu and select SERVICE MODE
2. Select “run” to start Service Mode



6.7. DIAGNOSTIC

The diagnostic allows switching the relay and set the current loop output current of the instrument for diagnostic purposes e.g. to test or measure the current loop connection.

WARNING



The instrument will switch relays and set the current loop output current to conditions which NOT equals defined instrument output states. This can lead to incorrect instrument signalling.

How To – Activate Diagnostic

1. Go to the Instrument Menu and select DIAGNOSTIC
2. Select “run” to start Diagnostic
3. Accept Warning with “cont.”

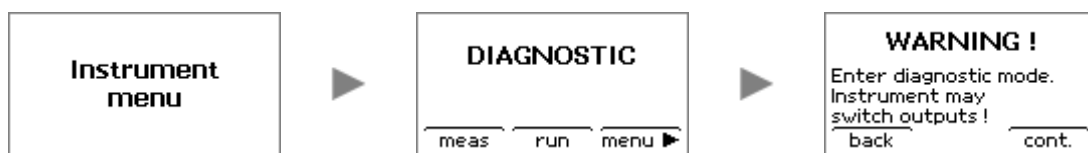

How To – Test current loop

1. Go to the Instrument Menu and activate diagnostic
2. Select Current loop and “run” to test
3. Change current loop output current

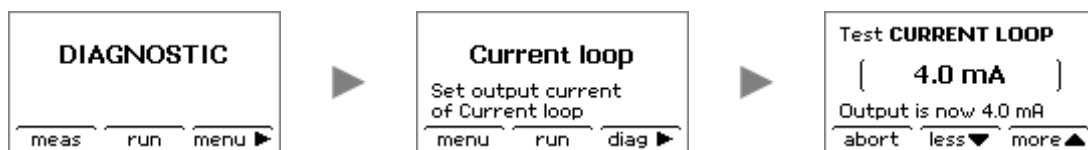

How To – Test relays

1. Go to the Instrument Menu and activate diagnostic
2. Select Relays and “run” to test
3. Select Relay to test with “next ▶” and “switch” relay energised or not

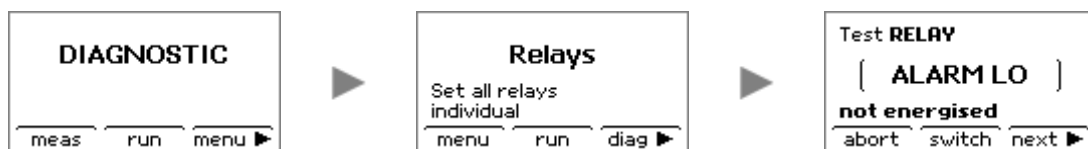

6.8. MEASUREMENT RANGES

The device supports the following measurement ranges:

	LOW RANGE (optional)	STANDARD RANGE	HIGH RANGE (optional)
Signal range (Isobutene/isobutylene equivalent)	0 ... 20 ppm	0 ... 100 ppm	0 ... 2000 ppm
Resolution	0.01 ppm	0.1 ppm	1 ppm
Recommended SPAN Gas for calibration	20 ppm Isobutene/isobutylene	100 ppm Isobutene/isobutylene	2000 ppm Isobutene/isobutylene
Recommended ZERO Gas for calibration	Synthetic Air	Synthetic Air	Synthetic Air
Over range	24 ppm Isobutene/isobutylene	120 ppm Isobutene/isobutylene	2100 ppm Isobutene/isobutylene

6.9. RESOLUTION OF MEASUREMENT RESULT

The representation of the measurement result depends on the selected detection range:

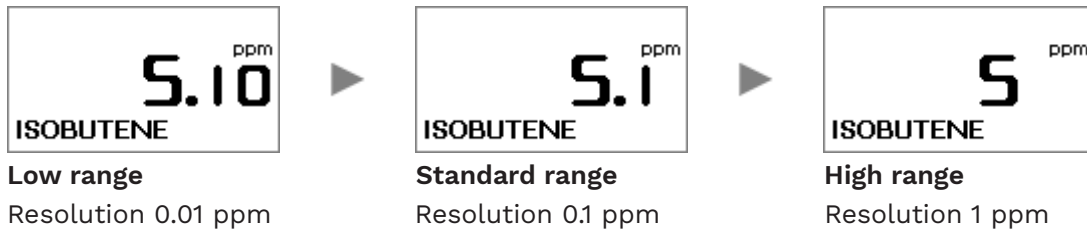

According to the value of the measurement result, the display value is rounded:

Measurement result	Rounded to resolution
result < 5 ppm	0.01 ppm
result < 10 ppm	0.05 ppm
result < 20 ppm	0.10 ppm
result < 50 ppm	0.50 ppm
result < 120 ppm	1.00 ppm
result < 200 ppm	2.00 ppm
result < 500 ppm	5.00 ppm
result < 1000 ppm	10.00 ppm

6.10. RELAYS

The device contains two alarm relays and one error relay to control other equipment. The two alarm relays will be activated if the device detects a gas concentration that lies outside the limit values. The error relay is activated if an ERROR is detected.

Each relay has a set of change over contacts (SPDT-single pole double throw). All relays are normally energised so that they are de-energised and are switched to a fail-safe condition in case of ALARM or ERROR.

During normal operation, the normally closed [NC] contacts are open. If an ALARM or ERROR is detected the relay contacts will change as follows:

- the normally closed contacts [NC] will close
- the normally open contacts [NO] will open

Relay nominal switching capacity [resistive load]:

ALARM LO	Relay	2 A / 30 V DC
ALARM HI	Relay	2 A / 30 V DC
ERROR	Relay	2 A / 30 V DC



NOTICE

Avoid peak currents higher than the 2 A maximum rating, which may be caused by inductive or capacitive loads (e.g. rotating beacons or signal horns). To operate such devices a secondary relay should be used or the peak current should be limited in another way.

6.11. OUTPUT STATES

STATE	RELAY			LED			CURRENT LOOP	
	Alarm LO	Alarm HI	Error	Alarm LO	Alarm HI	Status	4 ... 20 mA	0 ... 5 mA
Startup	energized	energized	energized	Off	Off	White flash	1 mA	0 mA
Menu / Maintenance	energized	energized	energized	Off	Off	Blue	1 mA	0 mA
Normal	energized	energized	energized	Off	Off	Green	4 ... 20 mA	0 ... 5 mA
Alarm LO	De-energized	energized	energized	Red flash	Off	Green	4 ... 20 mA	0 ... 5 mA
Alarm HI	De-energized	De-energized	energized	Red flash	Red flash	Green	4 ... 20 mA	0 ... 5 mA
Over range	De-energized	De-energized	energized	Red flash	Red flash	Red	22 mA	0 ... 5 mA
Under range	energized	energized	energized	Off	Off	Red flash	3 mA	0 ... 5 mA
Filter dirty	energized	energized	energized	Off	Off	Red flash	4 ... 20 mA	0 ... 5 mA
Error	energized	energized	De-energized	Off	Off	Yellow flash	2 mA	0 ... 5 mA

In case of purging

- Status LED is flashing green

7. MAINTENANCE AND SERVICE

WARNING



For safety reasons this product is supporting life and health. Equipment must be maintained and serviced by qualified personal only; otherwise the approval may be adversely affected, wrong readings could occur, and persons relying on this product for their safety could sustain serious personal injury or death.

WARNING



The device contains high voltage parts inside. Disconnect the power supply before maintenance and service.



NOTICE

The device contains electronic components, which react sensitively to electrostatic discharge (ESD). Work on or in the unit must be done only by qualified personal and in full compliance with the appropriate instructions and pertinent regulations.

7.1. MAINTENANCE INTERVALS

The maintenance intervals must be set keeping the environmental conditions in mind (especially in high-polluted environment).

A periodic inspection of the device must be performed at least once a year. The first inspection shall take 3 month after installation.

It is strongly recommended that the maintenance intervals below be respected in order to guarantee reliable operation.

Part Number	PARTS	MAINTENANCE INTERVAL	HIGH RANGE (optional)
0002184	Dust Filter	1 times a year / or every 3 month	For use in high-polluted environment, the dust filter and filter cartridge shall be exchanged every 3 month.
0002183	Filter Cartridge	1 times a year / or every 3 month	
0002598	Front Isolation	1 times a year	The front isolation shall be exchanged no later than 1 year after continuous operation.
0002670	Lamp	every 2 years	Parts shall be exchanged no later than 2 years after continuous operation.
0002940	Brushless Pump	every 2 years	
0002671	Sensor Block	every 2 years	

7.2. SAFETY SCREWS



Safety screw for the Filter Port Unit

DO NOT LOOSE THIS SCREW!!!



Safety screw for the Sample Port Unit

DO NOT LOOSE THIS SCREW!!!



WARNING

It is not allowed to unscrew the safety screws of the Filter Port Unit and Sample Port Unit.

7.3. HOW TO – OPEN THE DEVICE



Remove Locking Screw and Lid

1. Unscrew the cover locking screw.
2. Unscrew the lid of the enclosure.

Needed tools: Allen key

Remove Captive Screw

3. Unscrew the captive screw.

Needed tools: Torx wrench TX15

Swing Out Electronic Unit

4. Pull on the top of the board to swing out the upper electronic unit.

7.4. HOW TO – REMOVE THE PCU-PCB

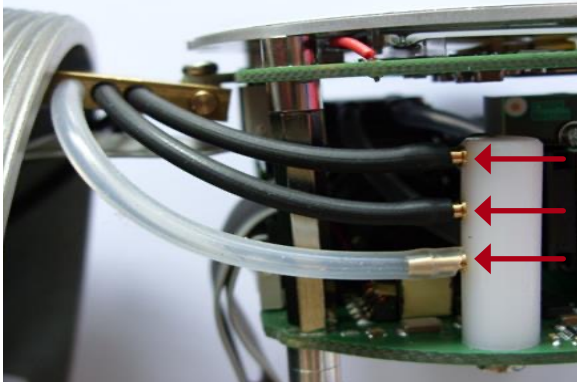

Remove Hoses

1. Remove the flexible hoses from the tube stubs.

When reassembling, pay attention to the order and orientation of the hoses.

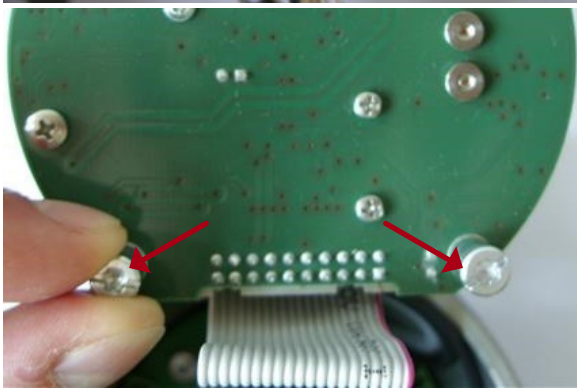

Unscrew Captive Screws

2. Unscrew both captive screws.



Remove PCU-PCB

3. Remove the PCU-PCB from the upper locking screw by pulling it down and pushing it left.

Don't remove the locking screw! This screw is glued in and may be very tight.

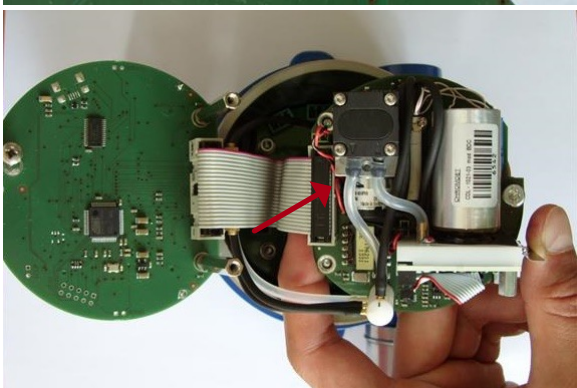

Remove Electrical Connection

4. Unplug the connecting cable.

7.5. HOW TO – REPLACE THE PID LAMP



Remove Spring Plate

1. Remove the spring plate from the two protruding studs by pulling it sideward. It is **not** required to loosen the red marked screws. There is already a distance between screw head and sensor.



Remove PID Lamp

2. Remove the PID lamp with a slight twisting motion until the O-ring dislodge the PID sensor block.
3. Disconnect the PID lamp power supply connector.

Do not unplug by pulling on the cable!



Replace Front Isolation

4. Remove the old front isolation from the PID sensor block by using a tweezers.
5. Place the new front isolation into the PID sensor block and make sure that the curvature shows to the lamp side and that the front isolation snaps into the circular groove at the ground of the cavity.

Do not bend and touch the front isolation.



Replace PID Lamp

6. Connect the PID lamp power supply connector.
7. Plug the PID lamp with a slight twisting motion into the PID sensor block until the O- ring engages.
8. Replace the spring plate. Do not fasten the two red marked screws.
9. Calibrate the device after installation of a new PID lamp.

7.6. HOW TO – CLEAN THE PID LAMP

On normal operation over time and for most of VOCs like Benzene, Toluene, Hexane, Acetone and others when concentration does not exceed several tens of ppm, it is not necessary to clean the lamp window.

Depending on the application it can be useful to clean the lamp. If PID readings often exceed 100 ppm or other heavy compounds are measured, then it is recommended to clean the lamp window. The interval between cleaning depends on concentration level and is governed by results of checking with use of calibrating SPAN Gas.

Cleaning procedure:

1. Remove the PID lamp like described in chapter 7.5.
2. For window cleaning it is recommended to use cotton buds saturated with pure methanol (analytic grade or better). Only wipe with light force onto the lamp window and rub in a circular motion. Repeat this 2-3 times.
3. After cleaning process take short brake of 1 min before the lamp will be installed into PID sensor block.
4. Switching on the device and after 15 min the calibration procedure can be started.

CAUTION

Follow common safety instruction for using methanol



Do not touch the lamp window during installation.

7.7. HOW TO – REPLACE THE FILTER PORT – FILTER CARTRIDGE

The filter cartridge must be replaced, if the error message “Filter dirty” will be shown on display.



Remove Filter Port – Filter Cartridge

1. Unscrew the old filter cartridge counter-clockwise.

Replace Filter Port – Filter Cartridge

1. Check that the filter port – seal is fitted and not damaged.
2. Check that the filter cartridge – seal is not broken.
3. Screw the filter cartridge into the filter port unit.
ONLY LIGHT FORCE IS REQUIRED!!!
4. Open the filter cartridge after installation by using the opener.

For detailed information, see chapter 4.3.



Calibrate the device after installation of a new filter cartridge.

7.8. HOW TO – REPLACE THE SAMPLE PORT – DUST FILTER

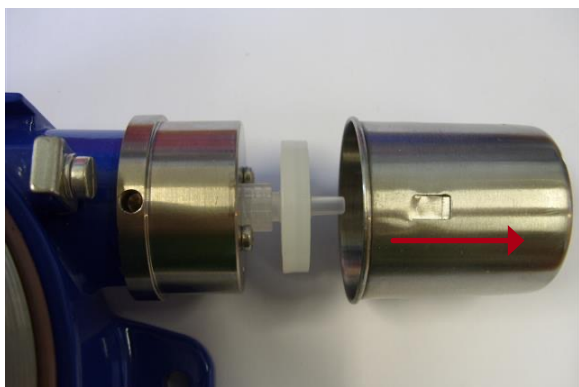

Remove Sample Port – Protection Cap

1. Remove the protection cap by pulling it sideward.



Replace Sample Port – Dust Filter

1. Unscrew the dust filter counter-clockwise.
2. Replace the dust filter by a new one.
3. Replace the protection cap.



Calibrate the device after installation of a new dust filter.

8. TECHNICAL DATA

Detector principle	VUV- Photoionization with 10.6 eV hollow cathode lamp with Ceramic Discharge Channel (optional 11,8eV lamp)	
Detection ranges	Range: 0 ... 20 ppm Isobutene * (isobutylene) 0 ... 100 ppm Isobutene * (isobutylene) 0 ... 2 000 ppm Isobutene * (isobutylene)	Resolution: 0.01 ppm 0.1 ppm 1 ppm
Display range	0 ... 20 000 ppm, depending on response factor of detected substance	
Lower detection limit	Typical 10 ppb *	
Display resolution	Dynamic up to 0.01 ppm	
Response time	T90 < 10 s *	
Signal integrity	Up to 100 ppm	typical > 98 % *
	Up to 2 000 ppm	typical > 95 % *
Influence of humidity	Humidity and temperature compensation at 0 ... 50 °C and 0 ... 90 % rH residual effect less than < 10 % FS	
Operating condition	-10 ... 55 °C 0 ... 95 % rH, non-condensing	
Storage conditions	-20 ... 60 °C 0 ... 95 % rH, non-condensing	
Gas sampling	Integrated diaphragm pump (about 250 ml/min) with flow detection Sample inlet with dust and water protection filter	
PID lamp life time	10,6eV: Min. 8 000 hours, typical more than 15 000 h 11,8eV: 4 months from delivery	
Alarms	2 adjustable alarm levels	
Power supply	9 ... 36 VDC, max. 4 W, recommended 24 VDC	
Signalisation	2 x LED (red) for alarms, 1 x LED (multicolour) for status	
Relays	3 x SPDT 30 VDC / 2 A (surge current), 2 x for alarms, 1 x for failure	
Analog output	Current loop, 4 ... 20 mA or 0 ... 5 mA	
Digital interface	RS485 (MODBUS)	
Calibration	Automatically two point calibration Zero gas via activated char coal filter, span gas via sample inlet	
Response factors	Selectable built-in response factors, changeable via remote service program	
User interface	Graphical display with backlight, magnetic keys	
Dimension, weight	200 mm x 370 mm x 133 mm (L x W x H), about 2200 g	
Ingress Protection	IP64	

*The indicated values were obtained under standardized conditions with 10,6eV lamp.
Test gas was isobutene (isobutylene) in synthetic air.

9. APPROVALS

9.1. MARKING, CERTIFICATES AND APPROVALS ACCORDING TO THE DIRECTIVE 2014/34/EU (ATEX)

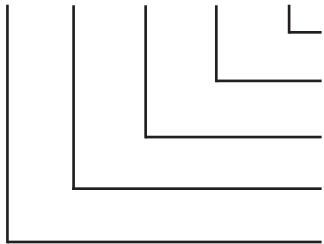
Product:	Stationary Photoionization Detector VOCPoint-*
Manufacturer:	WatchGas B.V. Klaverbaan 121 2908 KD Capelle a/d IJssel The Netherlands
Type of protection:	EN IEC 60079-0:2018/AC:2020-02, EN 60079-1:2014/AC:2018-09
Marking:	 II 2G Ex db IIC T6 Gb -40 °C ≤ Ta ≤ +60 °C
Type key:	
VOCPoint - R* - D* - L* - S* - C*	
	Position of thread hole for cable gland: 0 – left; 1 – right 0 – without alarm relays; 1 – with alarm relays 0 – Lamp 10,6 eV; 1 – Lamp 11,8 eV; 2...future options Digital interface: 0 – RS485; 1...future options Measurement range: 0 – standard; 1 low, 2 high; 3...future options
Rated voltage:	9 VDC ÷ 36 VDC
Maximum power dissipation:	4 W
EC-Type Examination Certificate:	FTZU 24 ATEX 0044X
Quality Assurance Notification:	2804
Year of Manufacture:	see Label
S/N:	see Label

Stationary Photoionization Detector VOCPoint

Type: VOCPoint-R0-D0-L0-S1-C0
ArtNo: 7162010
S/N: 5492250411 / 2023



Klaverbaan 121, 2908 KD,
Capelle aan den IJssel, The Netherlands
info@watchgas.com | www.watchgas.com



SPECIAL CONDITIONS FOR SAFE USE

- Ambient temperature range: $-40\text{ °C} \leq T_a \leq +60\text{ °C}$
- Verified values of the maximum gaps and minimum constructional length of flameproof joints of this enclosure are different from relevant minimum and maximum values mentioned in standard. To obtain information about joints dimension it is necessary to contact the manufacturer.
- Do not open the instrument when energised.
- Intensive electrostatic charging processes have to be prevented.
- Maintenance or repairment according to the type of protection "d" is only allowed by the manufacturer.
- IP64 – vertical, filter unit down

Cable gland

- The housing of the detector has to be equipped with flameproof cable gland Ex d IIC certified according to ATEX and or IECEx.
- M20 x 1,5; Torque 8 – 12 Nm

EMC Conformance according to the Directive 2014/30/EU

EN 50270:2006 Type 2, EN 61000-6-3:2007

9.2. MARKING AND CERTIFICATES ACCORDING TO IECEX

Product:	Stationary Photoionization Detector VOCPoint-*
Manufacturer:	WatchGas B.V. Klaverbaan 121 2908 KD Capelle a/d IJssel The Netherlands
Type of protection:	EN IEC 60079-0:2018/AC:2020-02, EN 60079-1:2014/AC:2018-09
Marking:	 Ex db IIC T6 Gb -40 °C ≤ Ta ≤ +60 °C
Type key:	VOCPoint - R* - D* - L* - S* - C*
	Position of thread hole for cable gland: 0 – left; 1 – right 0 – without alarm relays; 1 – with alarm relays 0 – Lamp 10,6 eV; 1 – Lamp 11,8 eV; 2...future options Digital interface: 0 – RS485; 1...future options Measurement range: 0 – standard; 1 low, 2 high; 3...future options
Rated voltage:	9 VDC ÷ 36 VDC
Maximum power dissipation:	4 W
EC-Type Examination Certificate:	IECEX FTZU 24.0007X
Quality Assurance Notification:	2804
Year of Manufacture:	see Label
S/N:	see Label

Stationary Photoionization Detector VOCPoint

Type: VOCPoint-R0-D0-L0-S1-C0
ArtNo: 7162010
S/N: 5492250411 / 2023



Klaverbaan 121, 2908 KD,
Capelle aan den IJssel, The Netherlands
info@watchgas.com | www.watchgas.com



SPECIAL CONDITIONS FOR SAFE USE

- Ambient temperature range: $-40\text{ °C} \leq T_a \leq +60\text{ °C}$
- Verified values of the maximum gaps and minimum constructional length of flameproof joints of this enclosure are different from relevant minimum and maximum values mentioned in standard. To obtain information about joints dimension it is necessary to contact the manufacturer.
- Do not open the instrument when energised.
- Intensive electrostatic charging processes have to be prevented.
- Maintenance or repairment according to the type of protection "d" is only allowed by the manufacturer
- IP64 – vertical, filter unit down

Cable gland

- The housing of the detector has to be equipped with flameproof cable gland Ex d IIC certified according to ATEX and/or IECEx.
- M20 x 1,5; Torque 8 – 12 Nm

EMC Conformance according to the Directive 2014/30/EU

EN 50270:2006 Type 2, EN 61000-6-3:2007

10. APPENDIX

10.1. ERROR MESSAGES



If an error is detected, the error message, followed by a short description, will be displayed. In this case, the normal operation of the device will not respond to gas and the current loop output will be the ERROR value.

DISPLAY	CAUSE	TROUBLESHOOTING
PID lamp	The PID lamp does not work	Check that the PID lamp connector is well connected
PID sensor	PID sensor does not work	Check that the cable between PID sensor and PCU-PCB is well connected
PID humid	PID humidity sensor error	
Relays	Relay does not work	Restart the device
Pump Motor	The pump motor does not work	Check that the Pump motor connector is well connected
Pump Blocked	The pump was blocked or got heavy load	Check sample gas input and dust filter. Check the tubing
Valve	Valve does not work	Check that the valve connector is well connected
LED	LEDs does not work	Restart the device
Filter dirty	The filter cartridge is dirty	Install a new filter cartridge

If the error code is still shown after a restart and troubleshooting, the device could be defective. For additional support, please contact the manufacturer.

10.2. MECHANICAL DRAWING

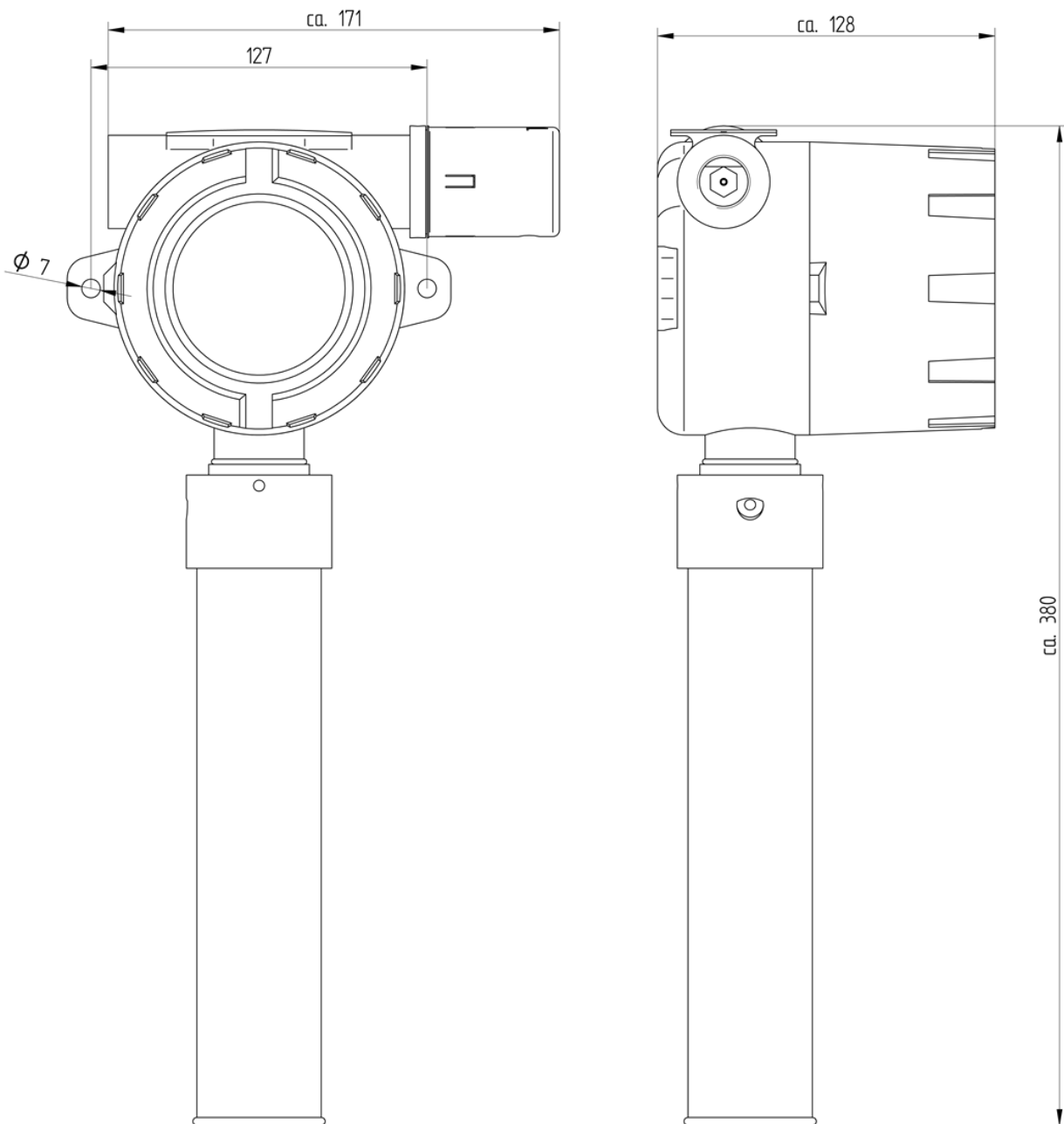

Dimensions shown in millimetres.

11. CONTACT INFORMATION

WATCHGAS EUROPE

Klaverbaan 121
2908 KD Capelle a/d IJssel
The Netherlands

info@watchgas.com

WATCHGAS AMERICAS

313 N. State Hwy 342
Red Oak, TX 75154, USA

info@watchgasusa.com

WATCHGAS APAC

Woods Square Tower 1,
12 Woodlands Square,
#11-71, Singapore 737715

+65 65179551
info@watchgas.com

12. ORDERING INFORMATION

12.1. VOCPoint WITH 10,6EV LAMP PART NUMBER: 716201 (100 PPM), 7162020 (20 PPM), 716203 (2000 PPM)

VOCPoint I. - II. - III. - IV. - V.

SPID2	-	R0	-	D0	-	L0	-	S0	-	C0
--------------	---	-----------	---	-----------	---	-----------	---	-----------	---	-----------

- I. **R0** Detection Range (Standard Range 0 ... 100ppm)
- R1 Detection Range (Low Range 0 ... 20ppm)
- R2 Detection Range (High Range 0 ... 2 000ppm)
- II. **D0** Digital Interface (RS485 with MODBUS)
- D1 Future Option
- III. **L0** Lamp (10.6 eV)
- IV. **S0** Alarm Relays (Without Relays)
- S1 Alarm Relays (With Relays)
- V. **C0** Cable Gland (Left)
- C1 Cable Gland (Right)

Manufacturer standard configuration for 10.6 eV
unless otherwise mentioned **VOCPoint-R0-D0-L0-S0-C0**

12.2. VOCPoint WITH 11,8EV LAMP PART NUMBER: 7162040 (100 PPM), 7162050 (1000 PPM), 7162060 (20 PPM)

I. - II. - III. - IV. - V.

VOCPoint	-	R0	-	D0	-	L1	-	S0	-	C0
----------	---	-----------	---	-----------	---	-----------	---	-----------	---	-----------





- I. **R0** Detection Range (Standard Range 0 ... 100ppm)
- R1 Detection Range (Low Range 0 ... 20ppm)
- R2 Detection Range (High Range 0 ... 2 000ppm)
- II. **D0** Digital Interface (RS485 with MODBUS)
- D1 Future Option
- III. **L1** Lamp (11.8 eV)
- IV. **S0** Alarm Relays (Without Relays)
- S1 Alarm Relays (With Relays)
- V. **C0** Cable Gland (Left)
- C1 Cable Gland (Right)

Manufacturer standard configuration for 11.8 eV
unless otherwise mentioned **VOCPoint-R0-D0-L1-S0-C0**

13. SCOPE OF DELIVERY

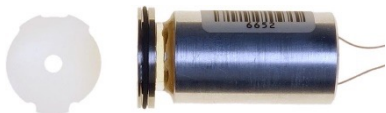

Part Number	DESCRIPTION
7162010 (100 ppm) 7162020 (20 ppm) 7162030 (2000 ppm) VOCPoint-R0-D0-L0-S0-C0	VOCPoint complete device with: <ul style="list-style-type: none"> • 1 x 10.6 eV VUV hollow cathode lamp with Ceramic Discharge Channel • 1 x Filter Cartridge • 1 x Dust Filter • 1 x Magnet Pen • 2 x Screw drivers for maintenance and service • Terminal connectors <ul style="list-style-type: none"> 1 x Power, 1 x RS485 (MODBUS), 3 x Relay • 1 x User manual • 1 x Declaration of conformity • 1 x Certificate of inspection
7162040 (100 ppm) 7162050 (1000 ppm) 7162060 (20 ppm) VOCPoint-R0-D0-L1-S0-C0	VOCPoint complete device with: <ul style="list-style-type: none"> • 1 x 11.8 eV VUV hollow cathode lamp with Ceramic Discharge Channel • 1 x Filter Cartridge • 1 x Dust Filter • 1 x Magnet Pen • 2 x Screw drivers for maintenance and service • Terminal connectors <ul style="list-style-type: none"> 1 x Power, 1 x RS485 (MODBUS), 3 x Relay • 1 x User manual • 1 x Declaration of conformity • 1 x Certificate of inspection

14. SPARE PARTS

Part Number	DESCRIPTION	
0002183	VOCPoint - Filter Cartridge	
0002184	VOCPoint - Dust Filter	
0002881	VOCPoint long life dust filter element	
0002404	VOCPoint - Magnet Stick	
0002452	VOCPoint - Sample Port - Protection Cap	
0002598	VOCPoint - Front Isolation Pack	
0002801	VOCPoint - PCU - PID Control Unit complete 10,6eV	
0002670	VOCPoint - Lamp Kit 10.6 eV	
0003008	VOCPoint - Lamp Kit 11.8 eV	

VOCPoint

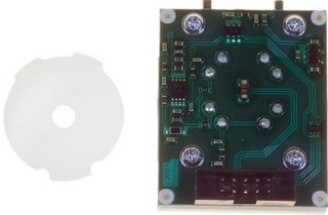
Stationary Photoionization Detector

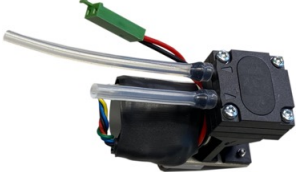
Part Number	DESCRIPTION	
0002671	VOCPoint - Sensor Block Kit	 The image shows a sensor block kit consisting of a circular white plastic component and a green printed circuit board (PCB) populated with various electronic components, including resistors, capacitors, and integrated circuits.
0002672	VOCPoint - Valve Kit	 The image displays a valve kit featuring a small green solenoid valve connected to a white plastic manifold. Two black hoses are attached to the manifold, and a red and white braided cable is connected to the valve.
0002940	VOCPoint - brushless pump kit	 The image shows a brushless pump kit, which includes a black brushless motor with a clear plastic housing and a white pump head. A clear plastic tube is connected to the pump head, and a green connector is visible on the side.

15. ACCESSORIES

Part Number	DESCRIPTION	
0002873	VOCPoint long life dust filter	
0002678	Cable gland Ex d IIC M20 x 1.5 Ø 10-14 mm	
0002719	Calibration Kit <ul style="list-style-type: none"> • Calibration Gas 100 ppm Isobutene (isobutylene) in air 34 l • Tube • Flow Controller with pressure indicator 	
C008920	Calibration Gas 100 ppm Isobutene (isobutylene) in air 34 l	
0002770	VOCPoint USB-RS485 communication kit 5m	