

XDI-PID

Hazardous area gas detector

Remote fixed gas detection
Specification Sheet ref C1505-C V2



KEY FEATURES

- Explosion proof
- Flexible output options
- Addressable or standalone
- Hyper terminal communications / RS232 – live data and set up with 232 adapter
- One man calibration
- Data logging
- 2 alarm relays plus fault relay or 3 alarm relay

The XDI-PID (photoionization detector) is used to measure a broad range of volatile organic compounds in the low ranges of 0 to 50ppm and 0 to 1000ppm. The unit is fully certified as a flameproof fixed monitor for use in hazardous areas. 4~20mA signaling with CANbus address enables the sensors to be networked via the WatchGas Combi control system or customer preferred monitoring systems

XDI-PID HAZARDOUS AREA GAS DETECTOR



Remote fixed gas detection
Specification sheet ref C1505-C V2

SPECIFICATIONS

CERTIFICATION	Explosion proof ATEX-IECEX UKEx II 2G Ex db IIC T6...T4 Gb II 2D Ex tb IIIC T85°C...T135°C Db
POWER SUPPLY	18 to 35vDC 24v nominal
OUTPUTS	3 wire analog 4~20mA: 4 wire CANbus <ul style="list-style-type: none"> • Optional Relays • Low alarm S.P.C.O: • High alarm S.P.C.O • Fault alarm S.P.C.O / overrange • Rating 0.5A @30vDC: • Inhibit option during servicing
LOGGING	Intervals - variable time Roll over/stop Storage - 2,880 readings
HOUSING MATERIAL	Copper free aluminium alloy, optional stainless steel
FINISH	Chemical resistant epoxy paint, Ral 9003 signal white Optional - Marine grade finish
INGRESS PROTECTION	IP64 + water shield IP65 with hydrophobic screen IP66
CABLE ENTRY	2 x M20 - 1.5 pitch - alternatives 25mm - 3/4 NPT
WEIGHT	1.6 kg
TEMPERATURE	-15°C to +55°C - safe area use For hazardous area use see temperature ranges on C1227 (Ex certification summary)
HUMIDITY	5 to 95% RH non-condensing
SENSOR TYPE	Photo ionisation - PID
TARGET GASES	VOC's with ionisation potentials <10.6 eV
ACCESSORIES	003-010 Collector Cone & Universal Fitting 003-020 Universal fitting (Test gas applicator / spray deflector) 003-035 Water Shield - stainless steel 008-311 Flow Block - nylatron 008-310 Flow Block - stainless steel 003-090 Duct Mount Kit 003-083 Detector Head Weather Shield 003-130 F1 Sensor Thermal Jacket
REPLACEMENT PARTS	010-644 PID Bulb* 010-645 PID Electrode Stack 010-646 PID Spring 010-647 PID Extraction Tool
RANGE	Isobutylene 0-200ppm (0-1000ppm max) Isobutylene 5ppb to 50ppm option see gas listing G645
OVERRANGE	Isobutylene 5000 ppm
RESPONSE TIME T90	<15 seconds
OPERATING LIFE	Expected 5 years (excluding replaceable lamp and electronic stack - *12 months continuous operation)

XDI-PID HAZARDOUS AREA GAS DETECTOR

Remote fixed gas detection
Specification sheet ref C1505-C V2

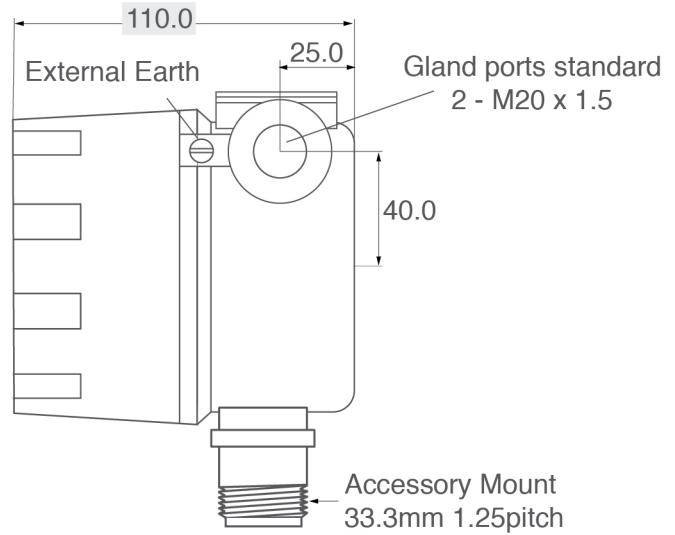
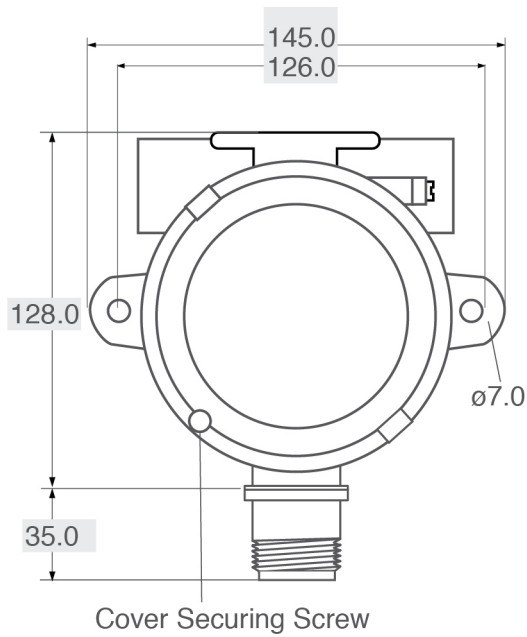

FOR MORE INFORMATION

www.watchgas.com
info@watchgas.com

WatchGas XDI-PID C1505-C V2 DS EN 04-03-24 v1.2 © 2024 WatchGas B.V.
WatchGas is dedicated to continuously improving its products. Therefore, the specifications and features mentioned in this datasheet are subject to change without prior notice.



Distributed by