

# XDI WIN-F6

## Hazardous area gas detector

C958 B



### KEY FEATURES

- ATEX explosion proof
- Rugged and reliable
- 3 alarm points
- CANbus / 4~20mA outputs
- Non intrusive adjustment magnets
- Addressable or stand alone
- One man calibration
- 2 alarm relays plus fault relay
- Data logging
- Back lit alpha numeric full status display

Remote Fixed Gas Detection offering local control and display.

The XDIwin-F6 Gas Sensor is capable of detecting a wide range of flammable gases. Standard 4~20mA signaling with CANbus address enables the sensors to be networked via the WatchGas Combi control system or customer preferred monitoring systems.

# XDI WIN-F6 HAZARDOUS AREA GAS DETECTOR

C958 B



## SPECIFICATIONS

WEIGHT	1.6 kg
TEMPERATURE	-15°C to +55°C – safe area use For hazardous area use see temperature ranges on C1010
HUMIDITY	0 to 99% RH Non-condensing
DISPLAY	2 line alpha numeric back lit status display: gas type, concentrating units, alarm levels, alarm status, low/ high/over range), sensor ID, inhibit
HOUSING MATERIAL	Copper free aluminium alloy, optional stainless steel
FINISH	Chemical resistant epoxy paint – RAL 9003 Signal White Optional – Marine grade finish
LID/BASE	Thread type with lock screw - 2mm
DATA LOG	Intervals - variable time Roll over/stop Storage - 2,880 readings
POWER SUPPLY	15 to 30vDC 24v nominal
OUTPUTS	<ul style="list-style-type: none"> <li>• 3 wire 4~20mA / 4 wire CANbus</li> <li>• Relays</li> <li>• Low alarm S.P.C.O</li> <li>• High alarm S.P.C.O</li> <li>• Fault alarm S.P.C.O</li> <li>• Rating 0.5A @30vDC</li> <li>• Inhibit option during servicing</li> </ul>
CABLE ENTRY	2 x M20 - 1.5 pitch - alternatives 25mm - 3/4 NPT
IP RATING	IP63 +universal fitting IP64 +hydrophobic filter IP65
SAFETY CERTIFICATION	Explosion Proof ATEX EII 2GD EEx db IIC T6...T4 Gb EEx tb IIIC T85°C...T135°C Db
GAS TYPE / RANGE	Flammable gases - LEL
ACCESSORIES	<b>003-062</b> Collector Cone & Universal Fitting <b>003-064</b> Universal fitting (Test gas applicator / spray deflector) <b>003-066</b> Flow Block - nylatron <b>003-090</b> Duct Mount Kit <b>003-083</b> Detector Head Weather Shield

# XDI WIN-F6 HAZARDOUS AREA GAS DETECTOR

C958 B

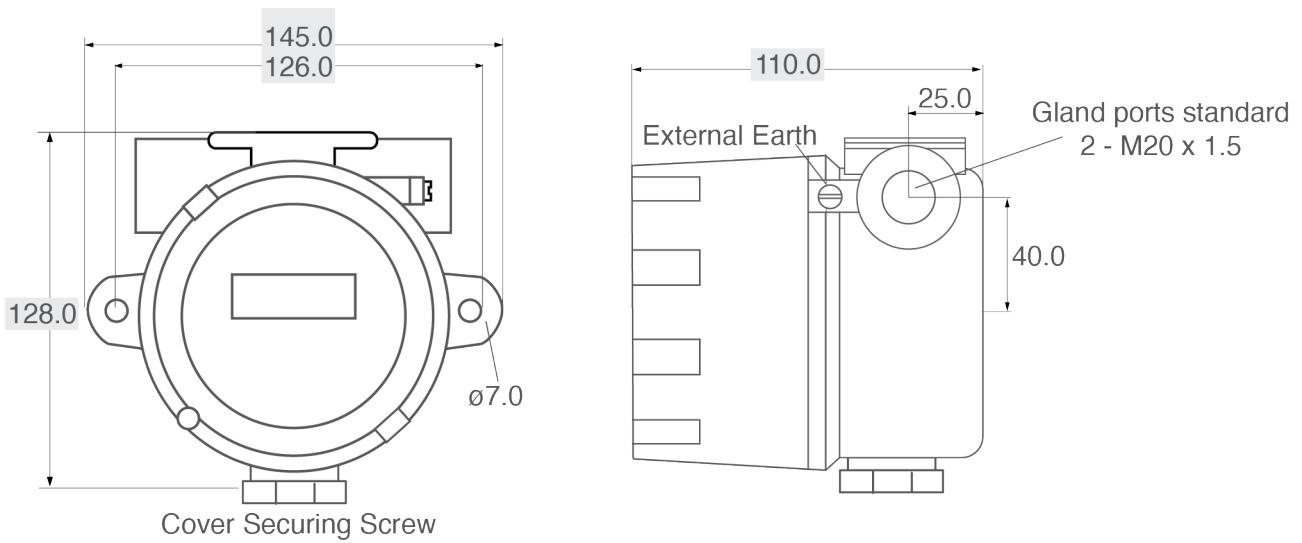

## THREE RELAY PCB DETAILS

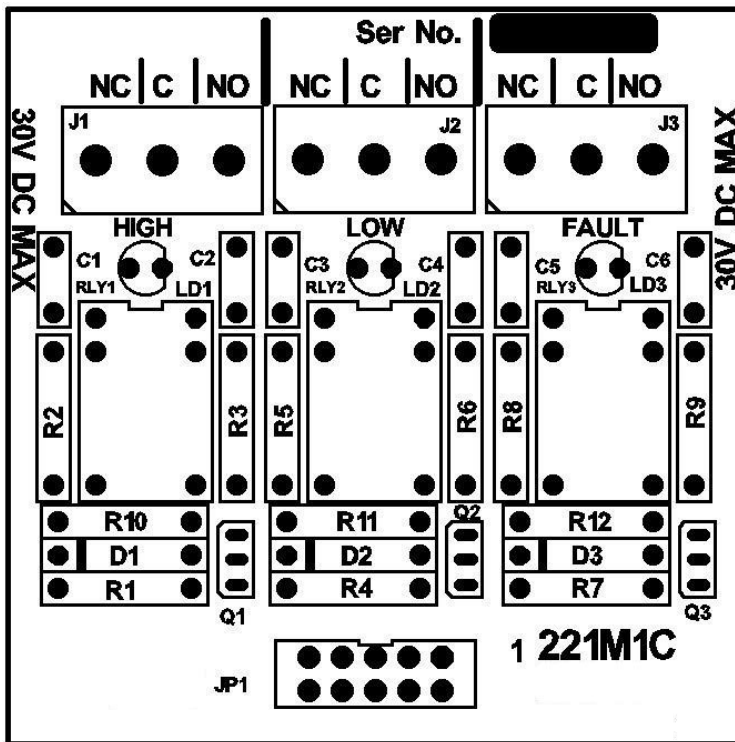

### FOR MORE INFORMATION

[www.watchgas.com](http://www.watchgas.com)  
[info@watchgas.com](mailto:info@watchgas.com)

Distributed by

WatchGas XDI- F6 C958 B DS EN 04-03-24 v1.2 © 2024 WatchGas B.V.  
WatchGas is dedicated to continuously improving its products. Therefore, the specifications and features mentioned in this datasheet are subject to change without prior notice.