

RED LINE PRIME – XDIWIN-F1 CARBON DIOXIDE GAS SENSOR

Specification sheet ref C1622 Av3



KEY FEATURES

- ATEX/IECEX explosion proof
- CANbus/ 4~20mA output
- Addressable or standalone
- 3 alarm points
- Robust and weatherproof
- Data logging
- Backlit alpha numeric full status display
- Automatic diagnostic system surveillance and fault monitoring
- 2 alarm relays plus fault relay or 3 alarm relays
- Adjustments - non intrusive magnets
- Backlit alpha numeric full status display

The Red Line Prime sensor uses proven non-dispersive single beam dual-wave length infrared principles to detect and monitor the presence of gases. This non-poisoning sensing technique relies on the target gas having a unique well-defined absorption signature. This is used to identify the presence of the target gas and is highly specific. Using a suitable infrared source, an analysis of the optical absorption through the gas allows the concentration of the target gas to be determined. All sensor driving is internal to the transmitter and full fault monitoring of the sensor and transmitter is continuous.

This information relates to the device operating continuously. The device may be calibrated for other gases.

CARBON DIOXIDE SENSOR	
Operation – continuous diffusion	NDIR (dual wave-length)
Measuring Range	Prime 2 0~2000 ppm 0~5000 ppm 0~2% volume 0~5% volume 0~10% volume
	Prime 3 0~100% volume
Accuracy	± 5% F.S.D
Warm up time to zero	< 30 seconds
Response time to target gas T90	< 35 seconds
Long term zero drift	± 5% F.S.D

RED LINE PRIME – XDIWIN-F1 CARBON DIOXIDE GAS SENSOR



Specification sheet ref C1622 Av3

ELECTRICAL DATA	
INPUT VOLTAGE – 3 WIRE DEVICE	18 to 35v DC – 24v DC nominal (polarity protected)
OUTPUT	4~20mA (Link selectable as sink or source)
FAIL SIGNAL	4~20mA reduced to 2mA
MAXIMUM CURRENT CONSUMPTION	130mA
MAXIMUM LOOP RESISTANCE IN SOURCE MODE	250R
RESOLUTION	0.15% of span
OUTPUT RESOLUTION	0.02mA
MAXIMUM OFFSET DRIFT	± 20uA
RELAYS	Low / high / fault alarms S.P.C.O. 0.5A @30v DC
LOGGING	Intervals - variable time Rollover/stop Storage - 2880 readings
DISPLAY	2 line alpha numeric backlit status display - gas type, concentration units, alarm levels, alarm status low/high/over-range, inhibit, sensor ID.
MECHANICAL DATA	
CERTIFICATION	Explosion proof ATEX-IECEX II 2G Ex db IIC T6...T4 Gb II 2D Ex tb IIIC T85°C...T135°C Db
REPLACEABLE PLUG IN SENSOR	In-situ
SENSOR ACCESSORY MOUNTING THREAD	33mm ø 1.25 pitch – 6 full threads
ENCLOSURE – TYPE XDI	Aluminium alloy – optional stainless steel RAL 9003 – Signal White
GAS SENSOR – TYPE F1	Stainless steel – 316 S16
WEIGHT	3.95 Kg
CABLE ENTRY	One – 20 mm 1.5 pitch Options 25 mm – 3/4 NPT
MOUNTING DETAIL	Two M5 (126 mm CRS)
APPROXIMATE DIMENSIONS-TERMINAL ENCLOSURE	126 mm dia. 83 mm deep

RED LINE PRIME – XDIWIN-F1 CARBON DIOXIDE GAS SENSOR



Specification sheet ref C1622 Av3

ENVIRONMENTAL DATA	
IP64 + water shield IP65 with hydrophobic screen IP66	
OPERATING CONDITIONS	5 to 95% RH non-condensing
TEMPERATURE	-15 ~ +55°C - safe area use for hazardous area use see temperature ranges on C1227 (Ex certification summary)
STORAGE CONDITIONS	0~99% RH non-condensing -20 ~ +60°C

ACCESSORIES

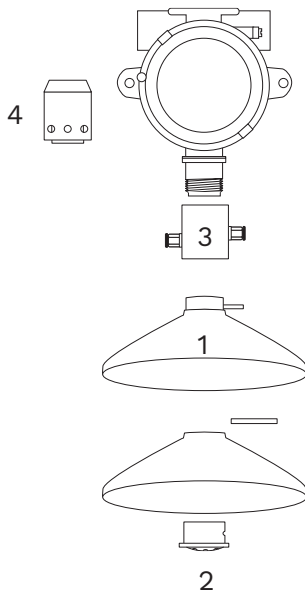

1. Collector Cone + universal fitting
 2. Universal Fitting (Test gas applicator spray deflector)
 3. Flow Block - nylatron
 3. Flow Block - stainless steel
 4. Water Shield - stainless steel
- Duct Mount Kit
--- Detector head Weather Shield
--- F1 sensor Thermal Jacket



FOR MORE INFORMATION

www.watchgas.com
info@watchgas.com

WatchGas RED LINE PRIME-XDIWIN-F1 DS C1622 EN 04-03-24 v1.0 © 2024 WatchGas B.V.
WatchGas is dedicated to continuously improving its products. Therefore,
the specifications and features mentioned in this datasheet are subject to change
without prior notice.

Distributed by