

# XDI-(win)-15/30J-(win)

## TOXIC/OXYGEN – TRANSMITTER (PCB326) (PCB198)



Set Up procedure Toxic/Oxygen

Technical Sheet ref C1882B

### Setting up a pre calibrated Transmitter (Cell replacement) A

New sensors are supplied ready to connect to the system with all jumpers inserted. This procedure shows how to recalibrate as part of a routine maintenance or cell replacement.

1. If bench testing the PCB see section B3
2. Using a digital mV meter measure across test pins TP2/3 and adjust Zero pot RV2 until LED D9 goes green for 4mA (zero) = 4mV (sensor bridge zero) see B9
3. Apply a known test gas to the sensor (e.g. 100ppm CO) for 1 minute at a flow rate of 1 litre to give a 13mA = 11mV across test pins TP2/3, adjust gain pot RV4 for correct mV reading.

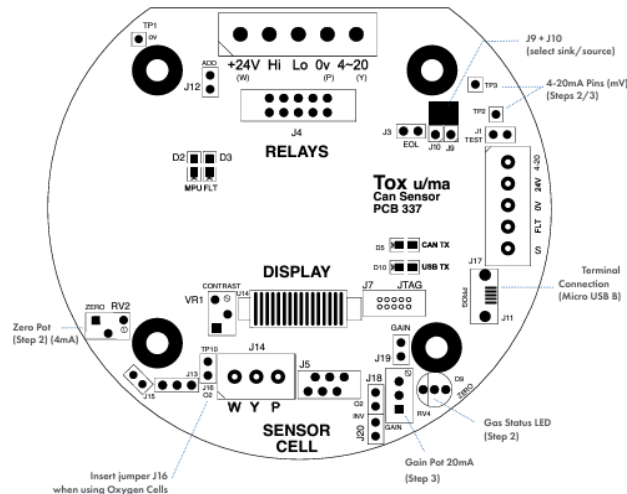

# WG Terminal Commands

D

Command	Use
A = Set CAN address	Sets the CAN address
G = Select gas type	Select the gas type from a list
Z = Zero	Press when no gas on sensor to give zero
S = Span	Use when calibration gas applied,
H and L change reading	
D = Enter calibration date	Enter the calibration date
Y = Toggle auto zero	Auto zero is ON or OFF, small drift is cleared
H = Set high alarm	Sets the high alarm threshold
L = Set low alarm	Sets the low alarm threshold
O = Set over range alarm	Sets the over range alarm threshold
P = List command	List these commands on screen
X = Exit calibration mode	Exit this PC mode
\$ = Initialise this sensor	Use on new PCB to set gas type to Flam
U = Alarm direction	Sets rising or falling alarms
R = Range	Allows a change in maximum value
N = Decimal points	Toggles between 1 and 2 decimal places
E = Edit user gas text	Choose gas description
B = Toggle deadband	Deadband of 2.5% can be on or off
F = Toggle fault Input	External fault input contact can be disabled
K = Select Input	Used to select the input from between Input J6 to input J14 (Toxic Only)
# = Local Relay Setup	Used to change the function of the 3rd relay from Fault to Over-Range
V = View gas log	From current log, display how many historical readings to display, up to 2880
% = Clear gas log	Set all 2880 log readings to 0.00
I = Log interval log	Choose how many seconds between each reading and whether the log will roll over or stop at 2880 (60 second interval and 2880 readings = 48 hours)
Space Bar = Enter Data / Load Data	Used to load sensor information after connecting to WG Terminal Used to load sensor information after connecting to WG Terminal
W = Set 4-20mA output	Adjusts the digital 4-20mA Output values
* = Toggle Baud Rate	Switches the Baud rate between 20kBits and 40kBits.

An example of continuous data output to the PC from a Flammable sensor is shown below and is the format for all gas types.

**O**, **H** and **L** represent the Over Range High and Low alarms respectively. **D** indicates if a duplicate address is detected **F** indicates a fault present **I** shows that this sensor has its alarms inhibited under the **O H L** the **^ ^ v** represent the direction of the alarms. **L** is falling and **H** and **O** are rising. A(\*) under the letter(s) OHLDFI represents a detected state so in this example the sensor would be in high alarm and a fault present.

```
Flam %LEL
OHLDFI
^^v
-*-*-*Gas val = 35.6
```

'Gas val 35.6' represents the value of the gas present at the sensor head. Pressing (R) on the PC causes a reset to occur. Gas type with address and serial number are then output to the PC together with alarms and calibration date. A full command list via PC is available by pressing the letter (P) which will relist on the PC.

F

# Using magnets or push buttons (set up)

E

The Combi sensors which have an LCD display fitted also incorporate 3 reed switches which can be activated using external magnets through the glass window of the flameproof XDIwin enclosure. **These magnets do not act instantly and have to be in close proximity to L, M and R on the front display for a few seconds to activate a software setup function.**

**The left magnet** enters the Auto zero ON or OFF menu. This allows small drift changes in the sensor to be compensated for but is not operational when the sensor readings are greater than 5% of full scale. Therefore auto zero is inactive when a larger gas reading is present. When the remove magnets message appears, move the left magnet away and then the display shows if auto zero is ON or OFF. The left magnet puts auto zero ON and the right magnet turns it OFF. With no magnets present, the display will return to normal after a few seconds timeout.

**The right magnet** allows the CAN address of the sensor to be changed. When the ADDRESS menu is displayed with a prompt to remove the magnet, and then the display shows the address and that the right magnet decreases it whilst the left magnet will increase it. This is then stored in internal non volatile memory and the display will automatically revert to normal operation.

**The centre magnet** is used to inhibit the sensor. As with the left and right magnet functions the display requests that you remove the magnet and then the state of the inhibit appears on the LCD. The left magnet then puts the sensor into inhibit whilst the right magnet removes it. An amber LED on the front panel under the LCD flashes when the sensor is inhibited. When all magnets are removed, the display will revert to normal operation.

**The left and right magnets together allow the calibration menu to be used.**

Removing both magnets as instructed on the LCD presents the first part of this multi menu which is ZERO. With no gas present use the left magnet to increase the reading and the right magnet to decrease to achieve a zero reading on the display. A timer is displayed on the LCD and when this reaches 0, the next menu is displayed. This timer is 15 seconds approximately and is reset back each time a magnet is near, timeout can be speeded up by placing a magnet near to the centre position.

SPAN is the next part of the menu and gas should be applied to the sensor at this time.

The left magnet increases the gain and the right magnet reduces gain. The actual sensor value can be seen on the display to rise or fall respectively.

**LOW ALARM** is the next menu and left and right magnets increase and decrease this value.

**HIGH ALARM** is next followed by OVER RANGE alarm.

The direction of the alarms is displayed as ^ for rising and v for falling but these can be changed using left and right magnets together.

F

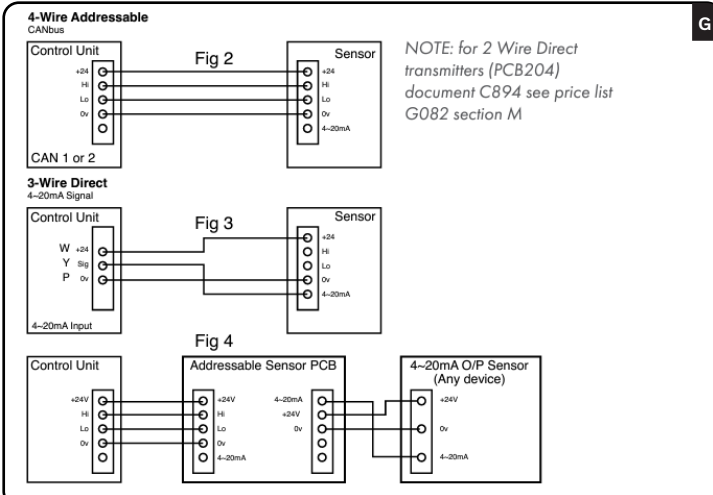

G

This document is not contractual and the equipment specification may be modified at any time without prior notice.