

# XDI-(win)-15/30J-(win)

FLAMMABLE – TRANSMITTER (PCB326) (PCB198)

Set Up procedure Flammable

Technical Sheet ref C1883C



## Setting up a pre calibrated transmitter (cell replacement)

1. If bench testing the PCB see section B4.
2. Check the sensor voltage at TP5 (0v) and TP8 (SV) and adjust RV1 if necessary (see section H Sensor Supply). **DO NOT EXCEED THE REQUIRED VOLTAGE OTHERWISE PERMANENT DAMAGE WILL OCCUR**
3. Using a digital mV meter measure across test pins TP2/3 and adjust Zero pot RV2 until LED D9 goes green for 4mA (zero) = 4mV (sensor bridge zero). (see B10/11)
4. Apply a known span gas to the sensor (56% LEL = 2.5% vol methane) for 1 minute at a flow rate of 1 litre to give a 13mA = 13mV across test pins TP2/3, adjust gain pot RV4 for correct mV reading.

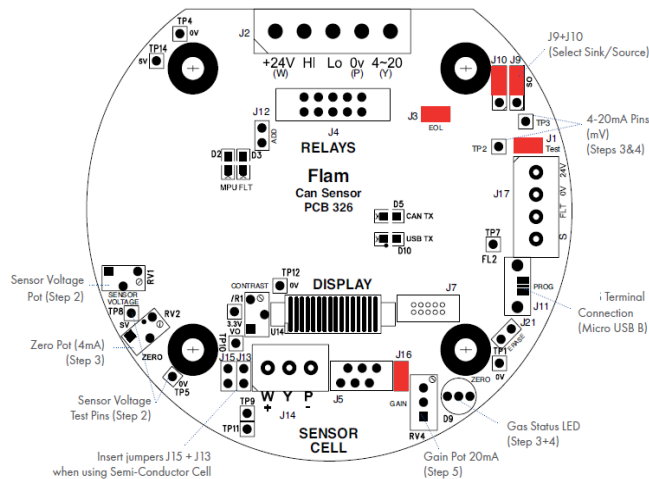

## Setting up a new transmitter utilising WG Terminal

1. Insert jumpers J10 and J9 position SO mode for 4-20mA source output.
2. Turn sensor voltage potentiometer RV1 anti-clockwise (minimum voltage).
3. Connect sensor to J14 terminal W-white Y-yellow P-pink.
4. For bench set up only connect 24V + and 0V to J2, connect jumper to J1 (4~20mA output test load), remove after set up.
5. Measure the sensor voltage at TP5 (0v) and TP8 (SV) and adjust by turning the Sensor Voltage RV1 pot for the correct reading See sensor supply table section H **DO NOT EXCEED THE REQUIRED VOLTAGE OTHERWISE PERMANENT DAMAGE WILL OCCUR**
6. Rotate Gain pot fully anti-clockwise (minimum span.)
7. Using a digital mV meter measure across test pins TP2/3 and adjust Zero pot until LED D9 goes green for 4mA (zero) = 4mV (sensor bridge zero).
8. Connect PC to sensor via WG terminal using USB-A to USB Micro-B cable (WG part No. 160-511) at 4800 baud connected to J11. The terminal output screen shows continuous data output/ commands and allows input from the PC keyboard.
9. Select COM Port – Note each new sensor connected to requires a new COM Port to be connected to.
10. Press ‘Space Bar’ loads sensor information. Ensure jumper J12 is fitted before programming. Press (C) to enter Calibration Mode, and Press (\$) to initialize the sensor.  
To update firmware contact WG.  
Press W to set 4-20mA parameters, use (L) and (H) to adjust 4mA, Press ‘Space’ to set, use (L) and (H) to adjust the 20mA, press ‘Space’ to set.
11. Then press (Z) on the PC to zero the reading.
12. Apply a known test gas to the sensor (56% LEL = 2.5% vol methane) for 1 minute at a flow rate of 1 litre to give a 13mA = 13mV across test pins TP2/3, adjust gain pot RV4 for correct mV reading.
13. When using a PC press (S) to enter span mode and using (H) or (L) adjust the reading to 56% LEL. Note – This adjusts the mA reading on TP2/3 when adjusted.
14. Press (space) to exit span and then (X) to exit the calibration mode.
15. Connect the sensor to an alarm panel and ensure that it reports in correctly. Note: Fit the end of line (EOL) link J3 if the sensor is to be installed at the end of the sensor cable.
16. If the sensor is fitted with a display – adjust the contrast potentiometer using VR1 pot.
17. Remove J1 test link for normal operation.
18. Ensure J12 address link is removed (this is only used when changing address from the alarm panel).
19. On completion and when used as an addressable sensor, future calibrations may be carried out

## Power supply

15 to 30Vdc 24v nominal

## Outputs

3 wire 4~20mA (Direct) / 4 wire CANbus (Addressable)

### Relays

when fitted Low alarm SPCO  
High alarm SPCO 0.5A @ 30Vdc  
Fault alarm SPCO  
Inhibit option during servicing

### Logging

Intervals – variable time  
Roll over/stop  
Storage – 2,880 readings

### Requires

USB A to USB micro B cable (WG part No. 160-511)  
PC or laptop (dedicated)  
WG Terminal (download from WG website)

# WG Terminal Commands

D

## Command

A = Set CAN address  
G = Select gas type  
Z = Zero

## Use

Sets the CAN address  
Select the gas type from a list  
Press when no gas on sensor to give zero  
Use when calibration gas applied,

S = Span  
H and L change reading  
D = Enter calibration date  
Y = Toggle auto zero

Enter the calibration date  
Auto zero is ON or OFF, small drift is cleared

H = Set high alarm  
L = Set low alarm  
O = Set over range alarm  
P = List command  
X = Exit calibration mode  
\$ = Initialise this sensor

Sets the high alarm threshold  
Sets the low alarm threshold  
Sets the over range alarm threshold  
List these commands on screen  
Exit this PC mode  
Use on new PCB to set gas type to Flam

U = Alarm direction  
R = Range  
N = Decimal points

Sets rising or falling alarms  
Allows a change in maximum value  
Toggles between 1 and 2 decimal places

E = Edit user gas text  
B = Toggle deadband  
F = Toggle fault Input

Choose gas description  
Deadband of 2.5% can be on or off  
External fault input contact can be disabled

K = Select Input

Used to select the input from between Input J6 to input J14 (Toxic Only)

# = Local Relay Setup

Used to change the function of the 3rd relay from Fault to Over-Range  
From current log, display how many historical readings to display, up to 2880

V = View gas log

Set all 2880 log readings to 0.00  
Choose how many seconds between each reading and whether the log will roll over or stop at 2880 (60 second interval and 2880 readings = 48 hours)

% = Clear gas log  
I = Log interval log

Used to load sensor information after connecting to WG Terminal  
Used to load sensor information after connecting to WG Terminal

Space Bar = Enter Data / Load Data

W = Set 4-20mA output

Adjusts the digital 4-20mA Output values

\* = Toggle Baud Rate

Switches the Baud rate between 20kBits and 40kBits.

An example of continuous data output to the PC from a Flammable sensor is shown below and is the format for all gas types.

O, H and L represent the Over Range High and Low alarms respectively.

D indicates if a duplicate address is detected F indicates a fault present I shows that this sensor has its alarms inhibited under the O H L the ^ ^ v represent the direction of the alarms. L is falling and H and O are rising. A(\*) under the letter(s) OHLDFI represents a detected state so in this example the sensor would be in high alarm and a fault present.

```
Flam %LEL
OHLDFI
^^v
-*-*-*Gas val = 35.6
```

'Gas val 35.6' represents the value of the gas present at the sensor head. Pressing (R) on the PC causes a reset to occur. Gas type with address and serial number are then output to the PC together with alarms and calibration date. A full command list via PC is available by pressing the letter (P) which will relist on the PC.

F

# Using magnets / switches (set up)

E

The Combi sensors which have an LCD display fitted also incorporate 3 reed switches which can be activated using external magnets through the glass window of the flameproof XDiwin enclosure. **These magnets do not act instantly and have to be in close proximity to L, M and R on the front display for a few seconds to activate a software setup function.**

**The left magnet switch** enters the Auto zero ON or OFF menu. This allows small drift changes in the sensor to be compensated for but is not operational when the sensor readings are greater than 5% of full scale. Therefore auto zero is inactive when a larger gas reading is present. When the remove magnets message appears, move the left magnet away and then the display shows if auto zero is ON or OFF. The left magnet puts auto zero ON and the right magnet turns it OFF. With no magnets present, the display will return to normal after a few seconds timeout.

**The right magnet switch** allows the CAN address of the sensor to be changed. When the ADDRESS menu is displayed with a prompt to remove the magnet, and then the display shows the address and that the right magnet decreases it whilst the left magnet will increase it. This is then stored in internal non volatile memory and the display will automatically revert to normal operation.

**The centre magnet switch** is used to inhibit the sensor. As with the left and right magnet functions the display requests that you remove the magnet and then the state of the inhibit appears on the LCD. The left magnet then puts the sensor into inhibit whilst the right magnet removes it. An amber LED on the front panel under the LCD flashes when the sensor is inhibited. When all magnets are removed, the display will revert to normal operation.

**The left and right magnet switches used together allow the calibration menu to be used.**

Removing both magnets as instructed on the LCD presents the first part of this multi menu which is ZERO. With no gas present use the left magnet to increase the reading and the right magnet to decrease to achieve a zero reading on the display. A timer is displayed on the LCD and when this reaches 0, the next menu is displayed. This timer is 15 seconds approximately and is reset back each time a magnet is near, timeout can be speeded up by placing a magnet near to the centre position.

SPAN is the next part of the menu and gas should be applied to the sensor at this time.

The left magnet increases the gain and the right magnet reduces gain. The actual sensor value can be seen on the display to rise or fall respectively.

LOW ALARM is the next menu and left and right magnets increase and decrease this value.

HIGH ALARM is next followed by OVER RANGE alarm.

The direction of the alarms is displayed as ^ for rising and v for falling but these can be changed using left and right magnets together.

## Addressable

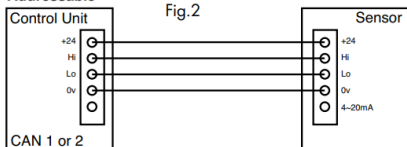

## 3-Wire Direct

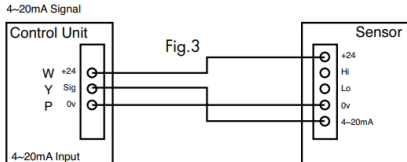

G

CAT300A	2V/300MA	SS10	2V/175MA
CAT170A	2V/175MA	CAT335A	2.5V/335MA
PRIME	4.0 V	CAT335B	2.5V/335MA
CAT335C	2.5V/335MA	CAT100A	2V/100MA
THE300A	2V/300MA	CAT165	2.2V/165MA
Sem1 (Refrigerant)	5.0 V	PID	5.0 V
Sem1 (Ammonia)	4.0 V		

H

This document is not contractual and the equipment specification may be modified at any time without prior notice.