

XDI-XDIwin – 15/30J

TOXIC/OXYGEN – TRANSMITTER (PCB204)



Set Up procedure Toxic/Oxygen

Technical Sheet ref C894Tv.6

Power Supply

15 to 30vDC 24v nominal

Outputs

2 wire	4~20mA output only
3 wire	4~20mA output
4 wire	CANbus
Relays	Low alarm SPCO High alarm SPCO 0-5A @ 30v DC Fault alarm SPCO Inhibit option during servicing
Logging	Intervals - variable time Roll over/stop Storage - 2,880 readings
Requires	RS232 lead – see 7 PC or laptop (dedicated) Hyperterminal (download from WG website)

Set up procedure:

Direct 4~20mA 2/3 wire (no processor U3-reduced component board)

New sensors are supplied ready to connect to a system with all jumpers inserted. This procedure shows how to recalibrate as part of routine maintenance or cell replacement.

The first part is to set up the 4-20mA section which is produced by the CELL circuit. Note some cells take time to stabilise. If used as 2 or 3 wire then only steps 1 to 5 are required.

1. Connect the cell to terminal J2 and use +24V, 0V and 4~20mA connections on terminal J10 for 3 wire (or +24V and 4~20mA for 2 wire - see note)
2. Measure voltage across test pins AG to Vo and adjust reading to zero mV using offset potentiometer
3. Measure the output current mV=mA at test pins TP1/TP2 and adjust reading to 4mV using 4mA pot

Command

Use

A = Set CAN address	Sets the CAN address
G = Select gas type	Select the gas type from a list
Z = Zero	Press when no gas on sensor to give zero
S = Span	Use when calibration gas applied, H and L change reading
D = Enter calibration date	Enter the calibration date
Y = Toggle auto zero	Auto zero is ON or OFF, small drift is cleared
H = Set high alarm	Sets the high alarm threshold
L = Set low alarm	Sets the low alarm threshold
O = Set over range alarm	Sets the over range alarm threshold
P = List command	List these commands on screen
X = Exit calibration mode	Exit this PC mode
\$ = Initialise this sensor	Use on new PCB to set gas type to Flam
U = Alarm direction	Sets rising or falling alarms
R = Range	Allows a change in maximum value

4. Apply span gas to cell and adjust 20mA pot to give correct mV reading at test pins TP1/TP2. NOTE: at 50% span gas, the mV reading at TP1/TP2 should be 12mV and the voltage across test pins AG and Vo should not exceed 1 volt so that 100% of range is achievable.
 5. Remove the span gas and re-adjust 4mA pot to 4mV if required.
4 wire CANbus / 3 wire 4~20mA (fully populated board) with processor communication
 6. With power applied ensure that MPU led is flashing and the CAN led is on or flashing.
 7. Connect RS232 micro USB or for earlier models Combi adapter (part no. 160-510) and lead (part no. 160-515) to J3 connector and to a PC running HyperTerminal at 4800 baud. Ensure jumper J29 is fitted before programming.
 8. The terminal output screen shows continuous data output/ commands and allows input from the PC keyboard. Pressing 'C' enters calibration mode
 - a. Press 'SHIFT \$' to initialise the sensor and reset to default "Flam 100% LEL" setting.
 - b. Then press 'G' to change the gas type to match the cell being used.
- NOTE: the range of the new gas has a default value but can be changed by pressing 'R'.**
- c. Press 'A' to change the address of this sensor if required
 - d. Press 'N' to select the number of decimal places to 1 or 2, (ie: dp=1 or dp=2)
 - e. With no gas applied and 4mV measured at test pins TP8/TP9 press 'Z' to zero the gas reading/see note.
 - f. Then apply span gas and press 'S' to enter span mode, obtain correct mV reading for test gas used by adjusting 20mA pot. The displayed reading can be made HIGHER by pressing 'H' or lower by pressing 'L'
 - g. Pressing 'SPACE BAR' will exit the span mode
 - h. Press 'V' to view log of sensor readings if required
 - i. Pressing 'X' will exit the calibration mode.

N = Decimal points	Toggles between 1 and 2 decimal places
E = Edit user gas text	Choose gas description
B = Toggle deadband	Deadband of 2.5% can be on or off
F = Toggle fault input	External fault input contact can be disabled
# = Normally energised	Low /high alarm relays and fault relay can be made normally energised

V = View gas log	From current log, display how many historical readings to display, up to 2880
% = Clear gas log	Set all 2880 log readings to 0.00
I = Log interval	Choose how many seconds between each log reading and whether the log will roll over or stop at 2880 (60 second interval and 2880 readings = 48 hours)

Using magnets (set up)

The Combi sensors which have an LCD display fitted also incorporate 3 reed switches which can be activated using external magnets through the glass window of the flameproof XDIwin enclosure. **These magnets do not act instantly and have to be in close proximity to L, M and R on the front display for a few seconds to activate a software setup function.**

The left magnet enters the Auto zero ON or OFF menu. This allows small drift changes in the sensor to be compensated for but is not operational when the sensor readings are greater than 5% of full scale. Therefore auto zero is inactive when a larger gas reading is present. When the remove magnets message appears, move the left magnet away and then the display shows if auto zero is ON or OFF. The left magnet puts auto zero on and the right magnet turns it off. With no magnets present, the display will return to normal after a few seconds timeout.

The right magnet allows the CAN address of the sensor to be changed. WHEN the ADDRESS menu is displayed with a prompt to remove the magnet, and then the display shows the address and that the right magnet will decrease it whilst the left magnet will increase it. This is then stored in internal non volatile memory and the display will automatically revert to normal operation.

The centre magnet is used to inhibit the sensor. As with the left and right magnet functions the display requests that you remove the magnet and then the state of the inhibit appears on the LCD. The left magnet then puts the sensor into inhibit whilst the right magnet removes it. An amber LED on the front panel under the LCD flashes when the sensor is inhibited. When all magnets are removed, the display will revert to normal operation.

The left and right magnets together allow the calibration menu to be used.

Removing both magnets as instructed on the LCD presents the first part of this multi menu which is ZERO. With no gas present use the left magnet

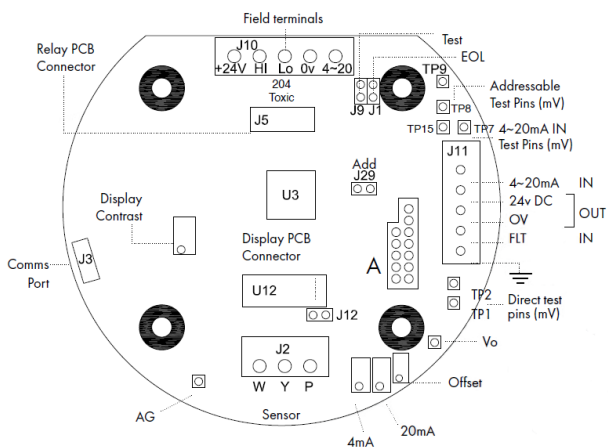

Fig.1

to increase the reading and the right magnet to decrease to achieve a zero reading on the displays. A timer is displayed on the LCD and when this reaches 0, the next menu is displayed. This timer is 15 seconds approximately and is reset back each time a magnet is near. Waiting till timeout is acceptable but this timeout can be speeded up by placing a magnet near to the centre position.

SPAN is the next part of the menu and gas should be applied to the sensor at this time.

The left magnet increases the gain and the right magnet reduces gain. The actual sensor value can be seen on the display to rise or fall respectively.

LOW ALARM is the next menu and left and right magnets increase and decrease this value.

HIGH ALARM is next followed by over range alarm. The direction of the alarms is displayed as ^ for rising and v for falling but these can be changed using left and right magnets together.

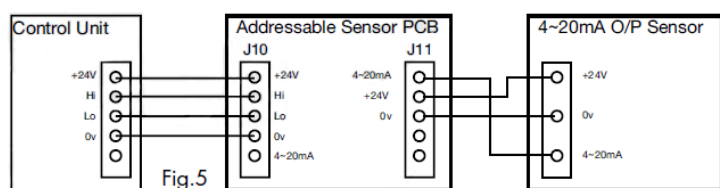
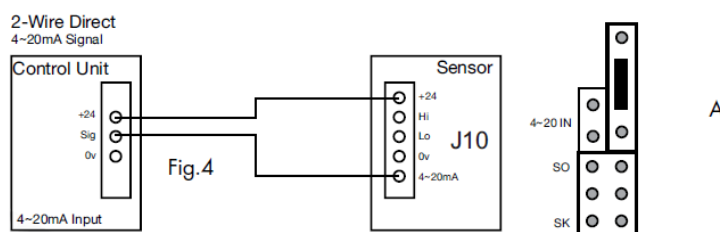
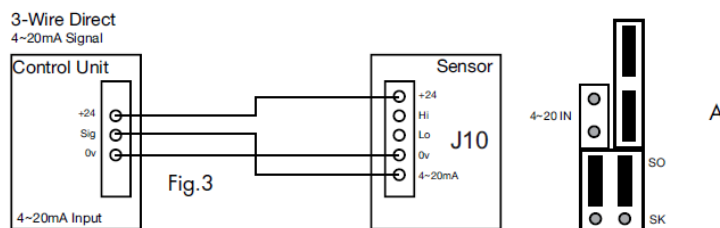
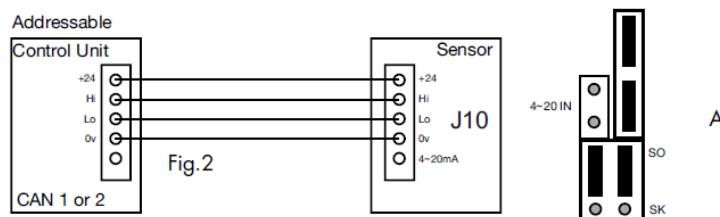

This document is not contractual and the equipment specification may be modified at any time without prior notice.