



OPERATING MANUAL

WATCHGAS 404+

we watch gas where you can't

CONTENTS

DESCRIPTION	3
TECHNICAL SPECIFICATION	4
INSTALLATION	5
COMMISSIONING	6
SERVICE – ROUTINE ATTENTION	9
TABLE OF LOWER EXPLOSIVE LIMITS	10
TABLE OF OCCUPATIONAL EXPOSURE LIMITS – P.P.M	10

ILLUSTRATIONS

Fig

1. Front View – Controls	10
2. Display Boards	11
3. Mother Board Detail and Field Terminals	12
4. Alarm Board – Component Layout	13
5. Sensor Termination	14
6. CV Transmitter – Toxic Oxygen	15
7. CV Transmitter – Flammable	16
8. XDI–XDI win / 30J Flammable Sensor	17
9. XDI–XDI win / 30J Toxic/Oxygen Sensor – 4/3/2 wire sensor	19
10. XDI–XDI win / 30J Prime Sensor	21
11. XDI–XDI win / 30J 4~20mA Input	23

Advisory

Note: 404/404+ setup – page 12 controller set up, page 13 alarm board.

SYSTEM DATA – EQUIPMENT OWNER USE				
Manufacture date:		Works Order No:		
Sensor type:	life:	life:	life:	life:
Gas:				
Range:				
Low alarm trip:				
High alarm trip:				
Fault Relay: Normally Energised – Latched				
Alarm Relays: Normally De–Energised – Latched				
Details:				

DESCRIPTION

The WATCHGAS 404+ is a multi channel combustible and toxic gas monitor, which can accommodate up to 4 sensor channels housed in wall mounting enclosure. Sensors may be added or removed as required, but should be carried out with the power to the unit switched off.

Each sensor continuously monitors for gas, the display will show the gas type being monitored, the current gas reading and the location of the sensors.

The gas alarms are activated at preset levels and will remain on until the gas clears, these in turn activate the appropriate alarm relays. The fault indicator is initiated should the sensor connecting lines become open/short circuit, or an electronic fault be detected.

The control unit requires an a.c. mains power supply and/or a low voltage d.c. power supply. When both are provided the low voltage d.c. acts as a standby supply in the event of an a.c. mains power failure.

MAINS ON LAMP (P)

GREEN indicates that power is being supplied to the control unit. When the optional standby battery is fitted loss of mains supply will result in the GREEN Mains ON Lamp changing to RED.

GAS ALARM

Will be indicated by a red LED and display channel changing to a red background with text indicating the alarm status. Fault conditions are indicated by amber displays.

SOUNDER

Initiated in the presence of a fault or gas alarm condition.

TEST

When pressed for 15 seconds alarm indications are activated.
If pressed for a further 15 seconds alarm relays will change state.

RESET

Used to mute the sounder and reset alarms, gas alarms cannot be reset until the gas concentration has decreased below the set alarm level.

ALARM RELAY INHIBIT

Pressing the reset pad for 15 seconds will inhibit the alarm relays which is indicated by one or more of the following indications depending upon the model build.

- 1 – front panel Amber Fault / Inhibit LED
- 2 – Motherboard mounted Amber LED D30 located adjacent to the inhibit relay
- 3 – Amber LED (Inh) located on each plug in alarm card.

To remove the inhibit press the reset pad for 15 seconds.

ZERO POTENTIOMETER

Meter zero adjust when the sensor is monitoring a gas free atmosphere.

SPAN POTENTIOMETER

Used to adjust the meter indication to read correctly when the sensor is subject to a test gas of known concentration.

ALARM SET SWITCH

Alarm trip points setting.

SENSOR CURRENT POTENTIOMETER

Sensor supply adjustment.

TECHNICAL SPECIFICATION

Number of channels	One, two, three or four channels
Outputs	<p>Common Relays – user selectable</p> <ul style="list-style-type: none"> • Low Alarm RL1 – D.P.C.O. normally energised or de-energised– default set ND • Latched or Unlatched – default set latched • High Alarm RL2 – D.P.C.O normally energised or de-energised– default set ND • Latched or Unlatched – default set latched • Third Alarm RL4 – D.P.C.O. normally energised or de-energised– default set ND • Latched or Unlatched – default set latched • Fault Alarm RL3 – S.P.C.O normally energised or de-energised– default set ND • Global Alarm Relay RL5 – S.P.C.O. changes on all alarms and is resettable at all times • Inhibit Indicator – RL6 – S.P.C.O contacts 1A@24v DC <p>Channel Relays</p> <ul style="list-style-type: none"> • High and Low Alarm relays S.P.C.O. normally energised or de-energised– default set ND • Latched or Unlatched – default set latched • All contacts rated 3A/230v AC
Sensor cable	<p>Flammable (catalytic) – 3 core, 1.5mm screened cable, mineral insulated copper sheathed or steel wire armoured – maximum cable loop resistance 20 ohms.</p> <p>Toxic/Oxygen – 3 core 0.5 mm screened cable, mineral insulated copper sheathed or steel wire armoured – maximum cable loop resistance 200 ohms.</p>
Power supply	230, 110v, AC 50/60Hz. or 24v DC (21–30 volts tolerance)
Power consumption	Per channel Normal operating condition: 3w Full alarm condition: 4.5w
Overload protection	1A fuse – AC 1 amp anti-surge fuse – DC 2 amp anti-surge fuse – Batteries.
Accuracy	±5% F.S.D
Repeatability	±2% F.S.D
Environmental	<p>Ambient operation temp: 0 to 50 degrees centigrade</p> <p>Storage temperature: -20 degrees to +60 degrees centigrade</p> <p>Humidity range: 0 to 90% RH</p> <p>Case Ingress Protection: IP52 – Option IP65</p>
Miscellaneous	CE Cert No. C511 Dimensions: 310mm (wide) x 265mm (high) x 75mm (deep) Weight: 3.5kg
Add on options	Standby battery 1 hour – Field installation – position the batteries so that they are supported by the battery locating bracket and then retained using the tywrap, connect the battery connectors to terminal blocks JP11 and JP12.

INSTALLATION

The WATCHGAS 404+ Series control instrumentation is designed for installation in a safe area only. Siting of the instrument should be chosen with regard to the following points:

- (a) Cable within the enclosure should be cut back to the minimum length and having been terminated should be kept away from electronic components and the ribbon cable. Cable requiring to pass from the bottom of the enclosure to the top should be run down the right hand side adjacent to the enclosure metalwork.
- (b) Away from sources of local heat and with room for adequate ventilation.
- (c) Within easy reach and audible distance of operating personnel.
- (d) Convenient to a separately fused power supply.
- (e) Incoming sensor cables and outgoing alarm annunciation.
- (f) Sensor cables to be electrically shielded i.e. M.I.C.C., steel wire armoured, screened cable.

To prevent any effect from earth currents the cable shielding should be grounded at one end only. The instrumentation should be subjected to a minimum of vibration and shock. Ascertain the voltage rating of the power supply to which the instrument will be connected

SITING THE SENSING HEADS

A key feature of the installation is the correct siting of the sensing head. Several considerations must be taken into account, the most important being the density of the gas.

Density (air = 1)			
Acetone	2.0	n-Hexane	3.0
Ammonia	0.6	Hydrogen	0.1
Benzene	2.8	Methane	0.6
n-Butane	2.0	n-Octane	3.9
Carbon Monoxide	1.0	n-Pentane	2.5
Ethane	1.0	n-Propane	1.6
Ethyl alcohol	1.6	Town gas	0.4-0.7
n-Heptane	3.5	Xylene	3.7

Under still air conditions, a 'lighter than air' gas such as methane leaking from a small orifice at ground level, will rise in a plume the shape of which approximates an inverted cone. As the gas rises, it draws air from the surroundings and creates a turbulence. Resulting from this there occurs rapid dilution and, unless a sensor is positioned within the plume, there will be no initial indication of a leak.

As gas continues to escape, the diluted concentration rises to ceiling level and begins to layer. In time the concentration at ceiling level will increase and this, in turn, will displace air downwards.

Dangerous levels will, therefore, tend to occur at ceiling level and the thickness of this layer will increase with the passage of time.

Ventilation of the room will of course alter the situation significantly but it should be remembered that if the ventilator is not at ceiling level, a dangerous concentration can still occur between the top of the ventilator and the ceiling.

For heavier than air gases such as propane or butane, the formation of dangerous layers occurs at ground level. These gases tend to behave like water and will run down gradients and pool at the lowest point.

The number of heads required in individual rooms is determined by the number of possible hazards in the vicinity.

WATCHGAS 404+

Gas leakage may occur around valves, flanges and anywhere where gas pipes are jointed. It may be possible to cover several probable gas leaks in one room by the careful siting of a single head. Cable ducts, trenches and manholes are also likely places where a build up of heavy gases may collect.

When siting a head in such places it is most important to ensure that there is no likelihood of flooding by water, or excessive dust which may block the sintered disc and prevent gas reaching the sensor.

When monitoring gases outside, those lighter than air will be quickly dispersed, but gases heavier than air will tend to form in layers and again cause a dangerous hazard. When siting heads outside prevailing winds must be taken into consideration and adequate protection given against wind and rain.

POISONING OF CATALYTIC SENSORS

Catalytic elements used in flammable gas sensors are liable to be rendered inactive due to 'poisoning' by certain groups of compounds. In general contact with any gaseous compound capable of producing an in-volatile residue upon heating is to be avoided.

Examples of such substances are:

- a. Silicon containing vapours, as emitted by silicone polishes, greases and oils.
- b. Petroleum vapours containing tetra-ethyl lead or other organo-metallic compounds.
- c. Phosphorus in the form of phosphate esters.

These compounds will permanently affect the detector and if their presence is suspected the response of the detector should be determined by the calibration procedure.

It is also possible that the reaction of the detector to a flammable gas could be inhibited by halogen containing gases such as chloroform, carbon tetra chloride and trichloro-ethylene. This effect is not permanent.

COMMISSIONING

Before applying power to the instrument ensure that all detector heads are connected to the sensor terminals on the printed circuit board (fig 2) and that each detector head is connected to its appropriate channel:



WARNING

DO NOT INSERT OR REMOVE ALARM CARDS FROM THE MOTHERBOARD WHILE THE POWER IS ON

- Switch on power to the instrument.
- Check that the green power lamp is on.
- Each channel alarm card has a green (ACTIVE) indicator located on the mother board (D102, D202, D302, D402).
- On power up these will flash for 60 seconds indicating that the sensors are stabilising, during this period all alarms are held in the off condition.
- Where an internal standby battery has been supplied the connectors should be made on JP11 and JP12.
- Re-set alarms by pressing the reset button located on the front panel.
- Allow ten minutes for the sensors to stabilise.
- Any flammable or toxic sensors should be adjusted to read zero by means of appropriate ZERO POTENTIOMETER marked (Z) on the alarm module, or for oxygen sensor adjust the s-span potentiometer for a reading of 20.8 repeat for Channel 2, 3 and 4.

CALIBRATION

Establish calibration figures with respect to the L.E.L. limit or the T.L.V. limit of the calibration gas being used. See page 11.

The following calibration gases are recommended:

Flammable gases – 2.5% methane in air.

Toxic gases – T.L.V. When using this gas ensure adequate ventilation.

If necessary zero each detector channel in clean air (for ambient oxygen monitoring the meter should be

adjusted to read 20.8% using the s–span potentiometer – disconnect one sensor lead to adjust zero. Apply the calibration gas to the appropriate head at a flow rate of approximately 1 litre per minute. When the meter reads a steady value adjust the Span Potentiometer marked (S) to obtain the correct reading for the calibration gas being used.

SERVICE ADJUSTMENTS

The following adjustments need only be made if the standard factory settings (see test certificate) are to be adjusted.

CALIBRATION WHEN USING 4~20MA SENSOR TRANSMITTERS

Where a sensor transmitter has been supplied the setting up procedure as described on pages 14 to 22 should be followed.

NOTE: Where a transmitter is used, adjustment of the alarm module calibration potentiometer is not required (factory set for 4~20mA input signals), gas calibration need only be carried out at the detector head end.

ALARM LEVEL ADJUSTMENT (LO/HI)

1. Alarm levels may be adjusted as follows:
 - For toxic/flammable gases zero the instrument in clean air using the zero potentiometer (for ambient oxygen monitoring the meter should be adjusted to read 20.8 using the s–span potentiometer).
2. Press the alarm set switch for approximately 2 seconds the sounder will bleep and the low alarm indicator will come on, the green power indicator will turn off, release the alarm switch.
3. Using the zero potentiometer adjust the digital display for the required low trip level reading, press the alarm set switch until the high alarm indicator comes on, release the alarm set switch.
4. Adjust the digital display to read the required high trip level reading and again press the alarm set switch both alarm indicators will come on.
5. Zero the digital display (toxic/flammable) or 20.8 for oxygen and press alarm set switch, alarm indicators will turn off and the green power indicator will turn on.

THIRD ALARM (AL3) SET UP PROCEDURE

The screen displays all required information simultaneously as well as the sensor’s name/location with a maximum of 16 characters.

The third alarm (AL3) is set using the potentiometer on the front panel PCB labelled RL4. This is a global alarm that applies to all four channels. One sensor zero level should be raised up to the desired alarm level by turning that channel’s zero pot. The Alarm 3 set pot should then be turned until the third alarm just activates default setting (80~100 FSD). The zero pot can then be adjusted back to normal setting (see page 11).

There are jumpers for setting the third alarm level relay to be normally energised/de–energised (jumper fitted for normally energised) and the alarm being latched/unlatched (jumper fitted for latched).

DISPLAY TEXT CHANGES

Gas type and units (8 characters), decimal places and sensor name/location are set up using a PC via a micro USB to USB lead using WatchGas terminal or hyperterminal software.

Connect the front panel to a PC using a micro USB lead, this should auto–detect and appear as a com port, the number of which can be found in windows ‘device manager’ ports for example. The terminal program should be set up using the same method and settings as the WatchGas combi panel (baud rate 2400).

The terminal window will appear as below. Follow the onscreen instructions:

WATCHGAS 404+

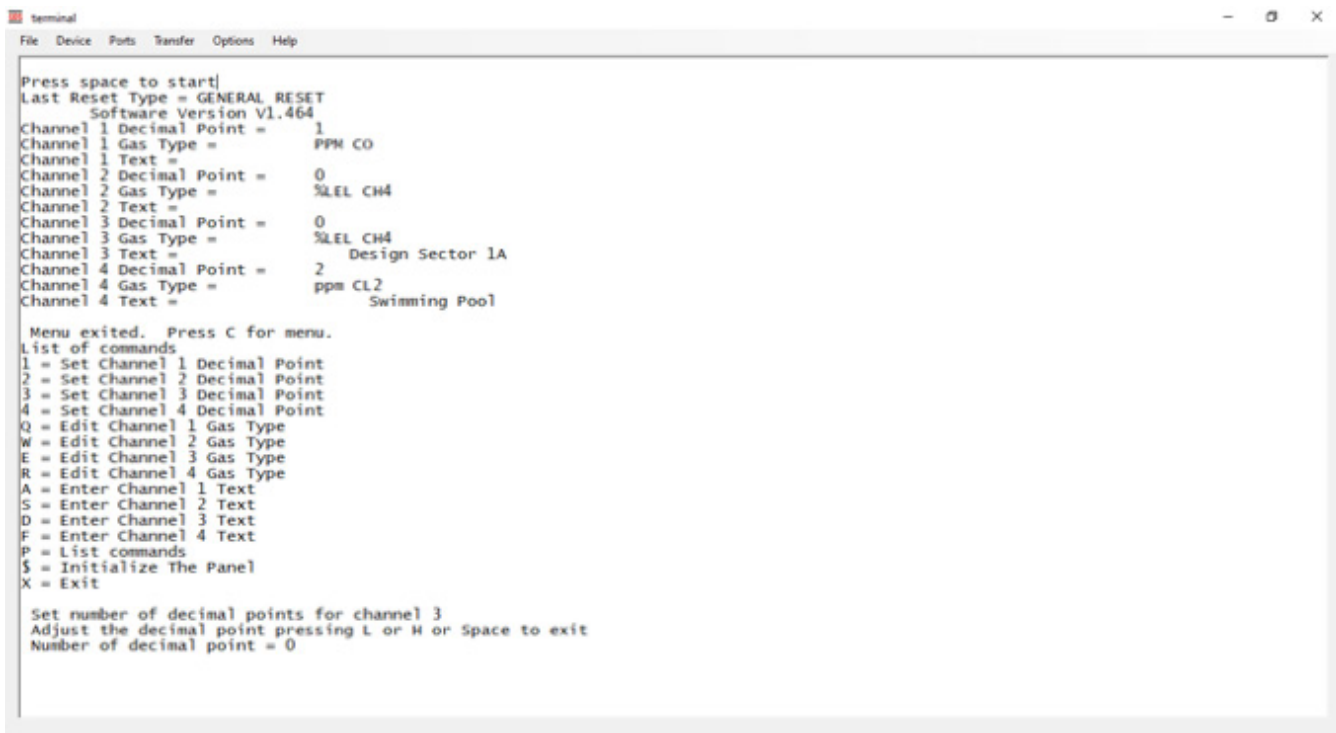

```
terminal
File Device Ports Transfer Options Help

Press space to start|
Last Reset Type = GENERAL RESET
Software Version V1.464
Channel 1 Decimal Point = 1
Channel 1 Gas Type = PPM CO
Channel 1 Text =
Channel 2 Decimal Point = 0
Channel 2 Gas Type = SLEL CH4
Channel 2 Text =
Channel 3 Decimal Point = 0
Channel 3 Gas Type = SLEL CH4
Channel 3 Text = Design Sector 1A
Channel 4 Decimal Point = 2
Channel 4 Gas Type = ppm CL2
Channel 4 Text = Swimming Pool

Menu exited. Press C for menu.
List of commands
1 = Set Channel 1 Decimal Point
2 = Set Channel 2 Decimal Point
3 = Set Channel 3 Decimal Point
4 = Set Channel 4 Decimal Point
Q = Edit Channel 1 Gas Type
W = Edit Channel 2 Gas Type
E = Edit Channel 3 Gas Type
R = Edit Channel 4 Gas Type
A = Enter Channel 1 Text
S = Enter Channel 2 Text
D = Enter Channel 3 Text
F = Enter Channel 4 Text
P = List commands
$ = Initialize The Panel
X = Exit

Set number of decimal points for channel 3
Adjust the decimal point pressing L or H or Space to exit
Number of decimal point = 0
```

Press the character on the left of the list of commands to change that specific setting. The sensor name has 16 available characters and the gas type has 8.

SENSOR SUPPLY ADJUSTMENT (CATALYTIC SENSOR)

Factory set – no further adjustment required unless a change of sensor type is being made.

For ease of setting, measurements are taken across a 1ohm resistor (located on each sensor board) which is connected in series with the supply to the detector head. Current required by each type of sensor is (VQ21–300mA/VQ23 DCP–335mA) therefore, measuring mV across the 1 ohm resistor at test point TP1 or TP2 (on the mother board) and sv test point on each sensor board, will provide a mV reading proportional to mA's supplied, adjustment may be carried out using the sensor volts adjustment potentiometer.

Alternatively the sensor voltage may be set at the detector head across terminals P and W (VQ21 2v/VQ23 DCP 2.5v) and again use the sensor volts adjust potentiometer.

4–20MA OUTPUT ADJUSTMENT

Adjustments: With the load connected to the appropriate 4~20–mA output terminal (typically 100 ohms) and a digital volt meter connected to the test pins TP3 + TP4 – ensure that the sensor is in clean air, and that the instrument is reading zero.

Adjust the 4mA potentiometer to read 4mV on the digital voltmeter.

Using the appropriate sensor zero potentiometer adjust the alarm panel digital display for full scale reading.

Adjust the 20mA output potentiometer until the digital voltmeter reads 20mV

Return the alarm panel digital display reading to zero by readjusting the zero potentiometer.

SERVICE – ROUTINE ATTENTION

The owner or occupier of the premises should place the supervision of the system in the charge of a responsible executive whose duty it should be to ensure the day to day operation of the system and to lay down the procedure for dealing with a gas alarm or fault warning. To ensure reliability an agreement should be negotiated for regular servicing. When a service contract cannot be arranged an employee with suitable experience of electrical equipment should be trained to deal with the more simple servicing and instructed not to attempt to exceed the scope of such training.

Liaison should be established with those responsible for maintenance of the building fabric or redecoration etc. to ensure that their work does not cause a fault or otherwise interfere with the operation of the gas alarm installation. Particular attention appertaining to the Detector Head.

The operating instructions should be kept available preferably with the control unit, all faults, service tests and routine attention given should be recorded.

DAILY

A check should be made that any fault condition which may be indicated is in fact being attended to and that all other indicators are normal.

WEEKLY

In plants involving a high risk process or having gases which may cause loss of sensitivity a check on calibration should be carried out.

TWICE YEARLY MAINTENANCE SCHEDULE

1. All zeros at the control unit to be checked, logged and aligned.
2. Each detector to be gas tested and reading logged (sensitivity checked).
3. Field indicators to be tested.
4. All alarm set points checked and re-aligned.
5. Lamp Test.
6. All faulty parts replaced where required.
7. All filter elements checked and replaced as necessary.
8. Power supply – complete functional check.
9. Visual inspection made to confirm that all cabling fitting and equipment is secure, undamaged and adequately protected.

FAULT DIAGNOSIS

Unable to zero meter

1. Sensor open circuit
2. Sensor leads incorrectly connected
3. Alarm card not positioned correctly

No front panel indication – Check ribbon cable is connected correctly

ACTION TO BE TAKEN IF THE APPARATUS ALARM SOUNDS:

- A. Extinguish all naked flames, including all smoking materials.
- B. Turn off all gas appliances.
- C. Do not switch on or off any electrical lights or appliances.
- D. Turn off the gas supply at the gas emergency control and/or (with L.P.G supply) the storage tank.
- E. Open doors and windows to increase ventilation

If the alarm continues to operate, even after an alarm re-setting action where appropriate, and the cause of the leak is not apparent and/or cannot be corrected, vacate the premises and immediately notify the gas supplier and/or the gas emergency 24 hour service in order that the installation may be tested and made safe and any necessary repair carried out.

WATCHGAS 404+

TABLE OF LOWER EXPLOSIVE LIMITS – L.E.L

The figures quoted below are taken from British Standards Institute publication BS EN 60079–20–1:2010 and show the L.E.L. of some of the more common gases and vapours:

GAS	L.E.L. % VOLUME
Acetone	2.5
Ammonia	15.0
Benzene	1.2
n-Butane	1.4
Carbon monoxide	10.9
Ethylene	2.3
Heptane	0.85
Hexane	1.0
Hydrogen	4.0
Methane	4.4
Propane	1.7
Pentane	1.1
Toluene	1.0
Xylene	0.9

TABLE OF OCCUPATIONAL EXPOSURE LIMITS – P.P.M.

The figures quoted below are taken from guidance note EH40 from the Health and Safety Executive and ACGIH.

GAS	8 HOUR – T.W.A. – P.P.M.
Hydrogen sulphide	5
Carbon monoxide	30
Sulphur dioxide	2
Nitrogen monoxide	25
Nitrogen dioxide	3
Chlorine	0.5
Ammonia	25
Ozone	0.1
Ethylene oxide	5

INDICATORS

L.E.L. – Lower Explosive Limit

PPM – Parts Per Million

% vol. – % Volume

Hi – High Alarm (Red)

Lo – Low Alarm (Red)

C1–C4 – Channel (Sensor)

– Fault Indicator (Amber)

– Power On (Green)

– Mains Fail (Red)

– Inhibit (Amber)

Reset – Sounder/Alarms

Test – Electronic System Test

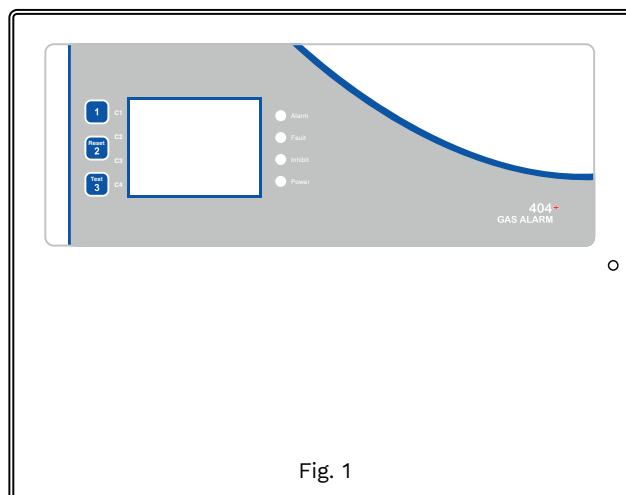
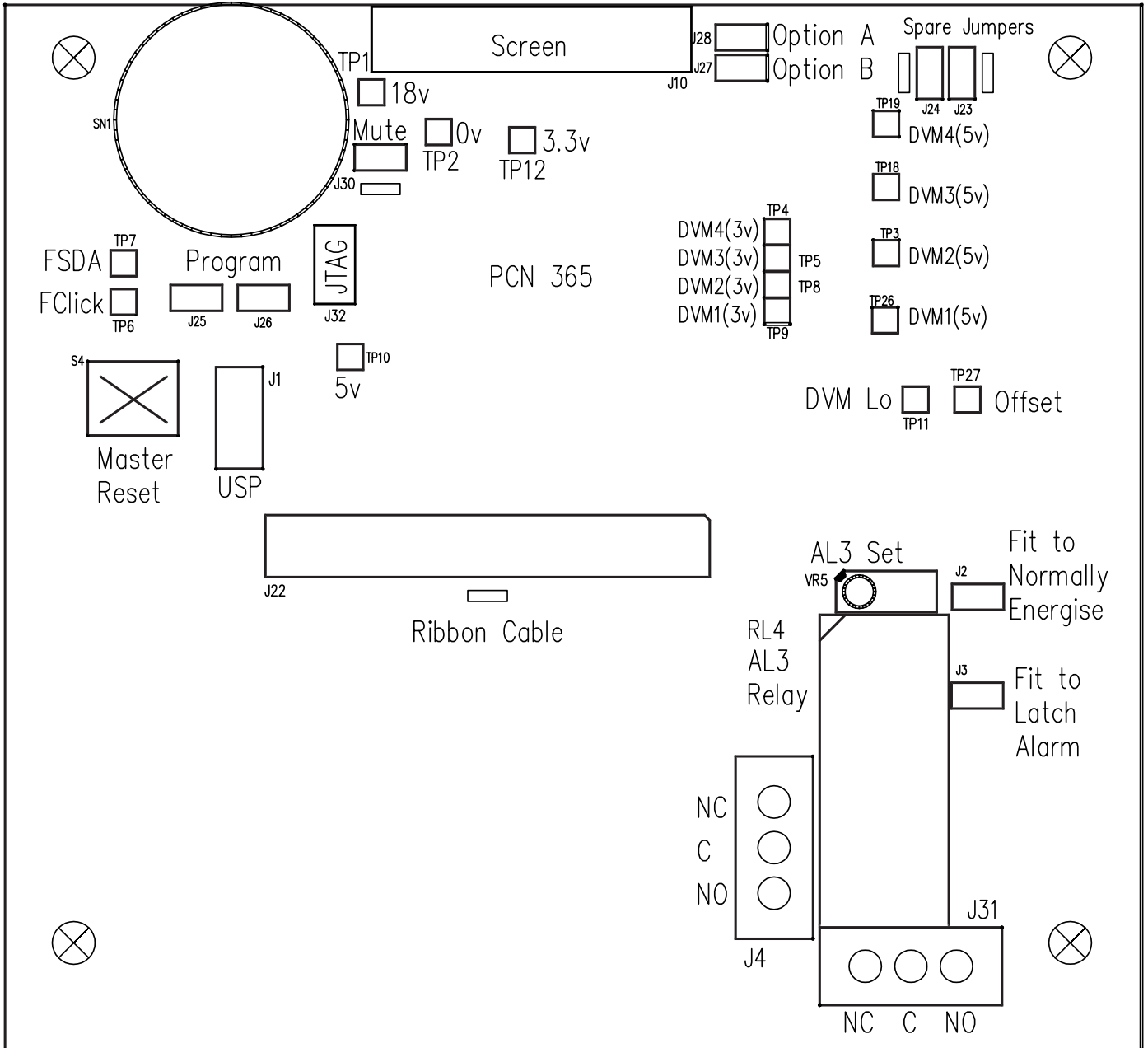

Fig. 1

Fig. 2



DISPLAY BOARD

RELAY SELECTION

Common Third Alarm Relay – Normally energised/Normally de-energised – (J2)

Fig. 3

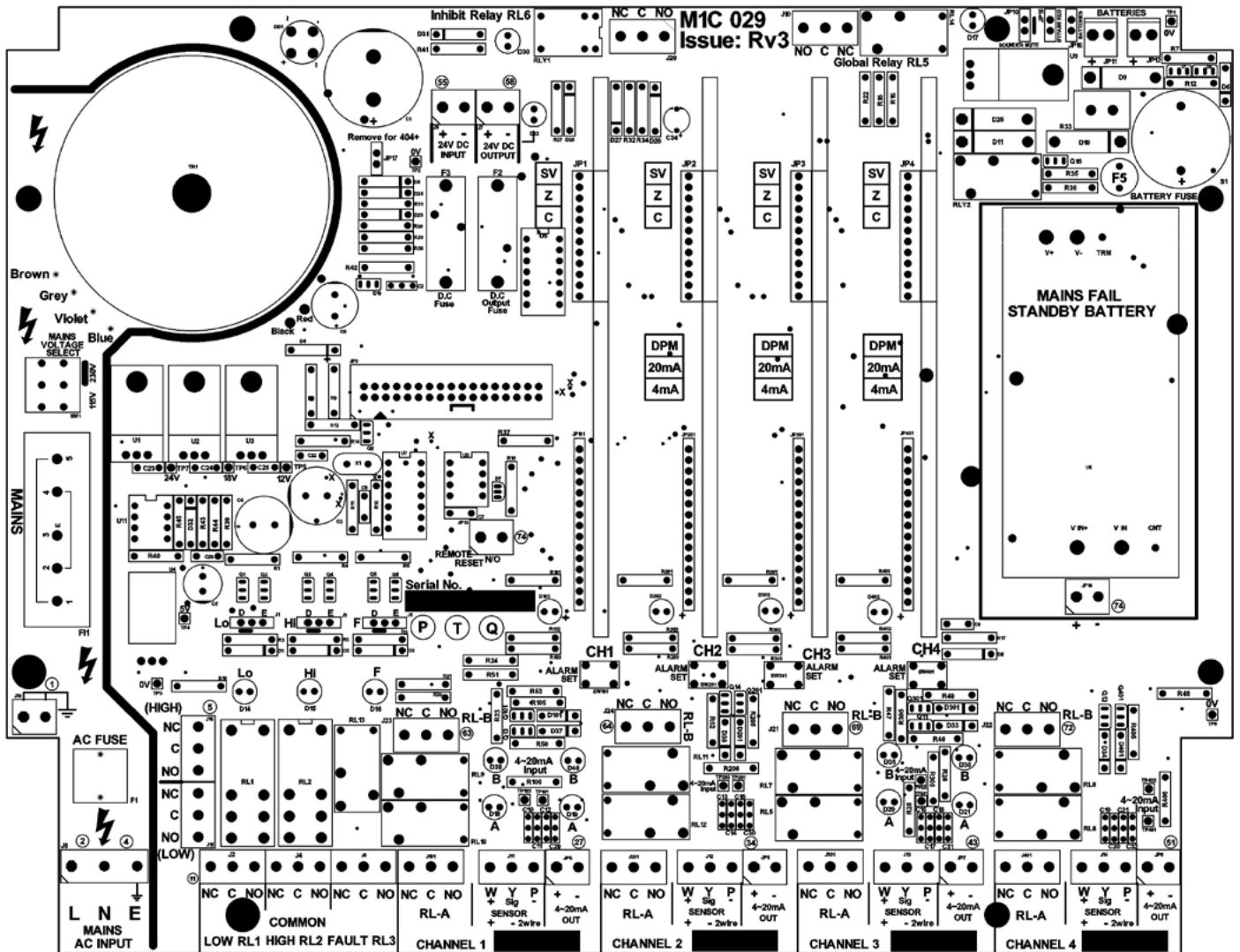

MOTHER BOARD

RELAY SELECTION

- Common High Relay – Normally energised/Normally de-energised – (J3)
- Common Low Relay – Normally energised/Normally de-energised – (J1)
- Global Alarm Relay – Normally de-energised
- Common Fault Relay – Normally energised/Normally de-energised – (J5)
- Inhibit Relay – Normally de-energised
- Channel relays (1–4) A/B (Lo/Hi) see alarm board page 14

SOUNDER PERMANENT MUTE

JP10 remove

STANDBY BATTERY

Connect leads to – (JP11 and JP12)

CONTROLLER SELECTION

- For operation as 404 JP17 should be fitted
- For operation as 404+ JP17 should be removed (JP17 located below sounder)

Fig. 4

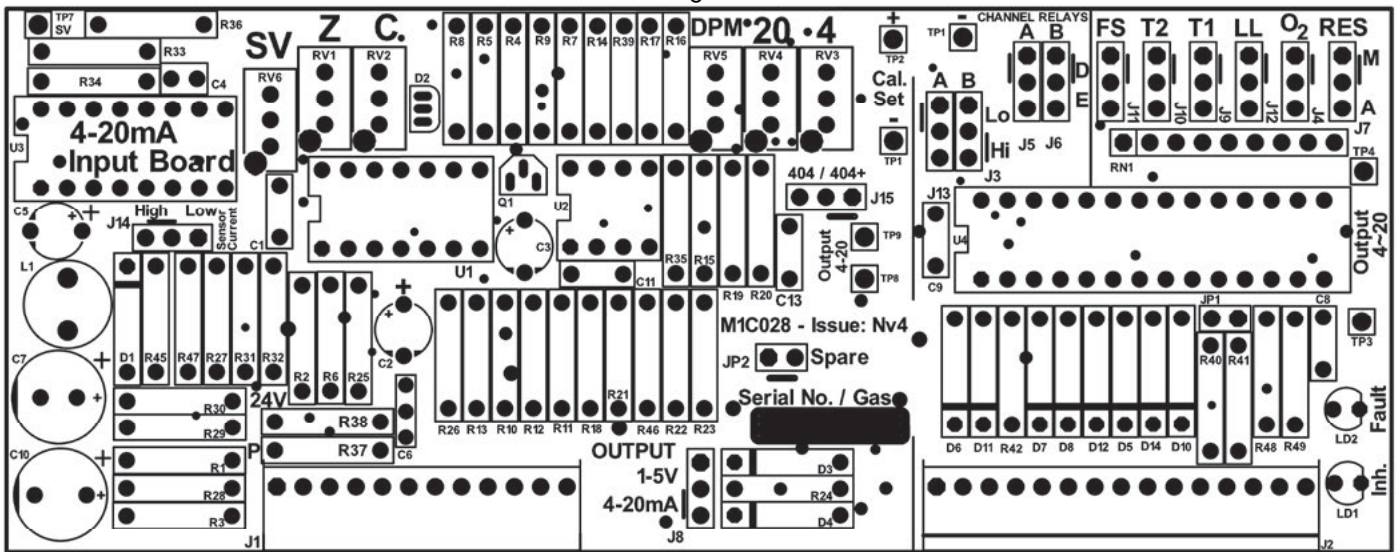

ALARM BOARD (PLUG IN)

RELAY SELECTION

Channel Relay A – Low/High Alarm – Lo/Hi – Factory set – Low
 Channel Relay B – Low/High Alarm – Lo/Hi – Factory set – High } for A+B
 Normally energised or de-energised – E/D – Factory set – De-energised (D)

AUTOMATIC OR MANUAL RESET – A/M

Oxygen Monitoring (factory set) – O2
 Oxygen Alarm Set Low/Low Alarm – LL
 Time delay to alarm – T1 – 10 secs
 T2 – 30 secs
 When used with WG300 Flow sample systems – FS

SENSOR SELECTION

24v (4/20mA input) P – Pellistor (mV input)

4-20MA OUTPUT

TP3/TP4

CALIBRATION

TP1/TP2

ADJUSTMENTS

Potentiometer RV1 – Sensor Zero
 Potentiometer RV2 – Sensor Calibration
 Potentiometer RV3 – 4~20mA signal output – 4mA adjust
 Potentiometer RV4 – 4~20mA signal output – 20mA adjust
 Potentiometer RV5 – WATCHGAS 404+ display span (factory set)
 Potentiometer RV6 – Sensor Supply

ALARM BOARD SELECTION

For operation as 404 JP1 should be fitted and J15 should be set to 404
 For operation as 404+ JP1 should be removed and J15 should be set to 404+
 (J15 located above SN block, J1 located below U4 (large IC))

Fig. 5

3 WIRE SENSOR

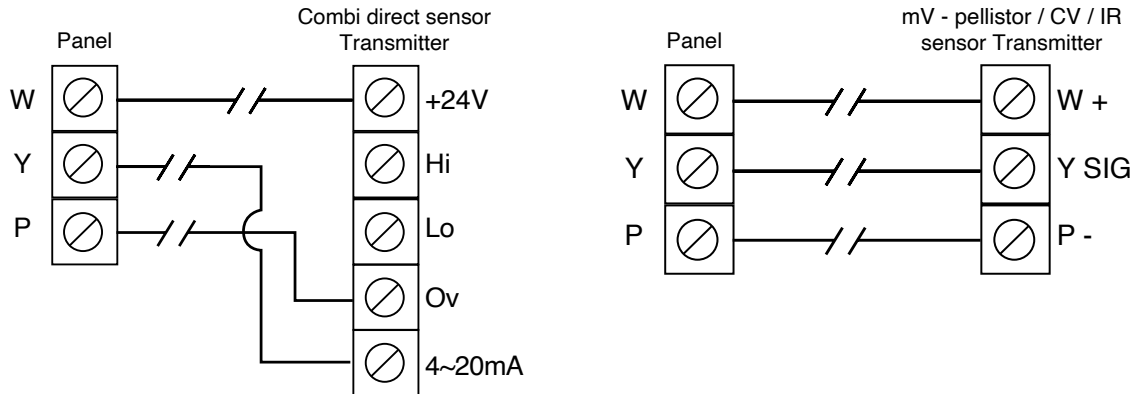

2 WIRE SENSOR

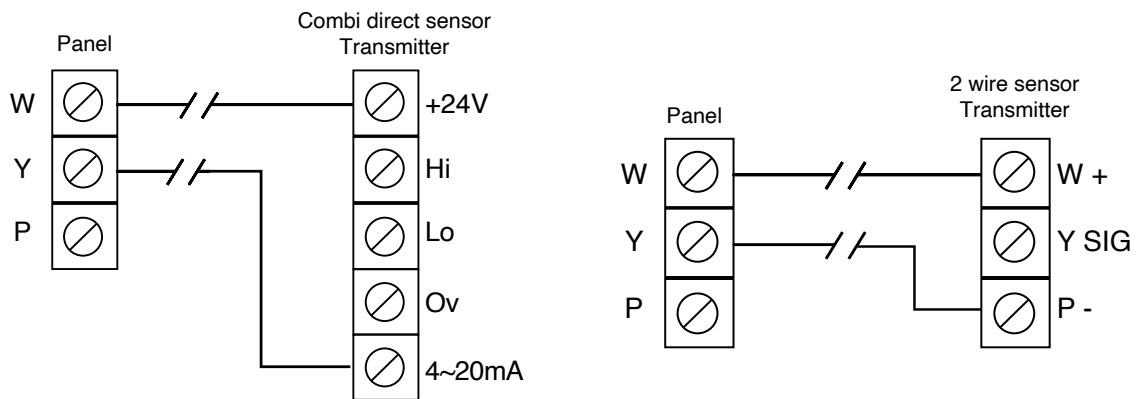

3 WIRE REDLINE (2 PCB) INFRA RED SENSOR

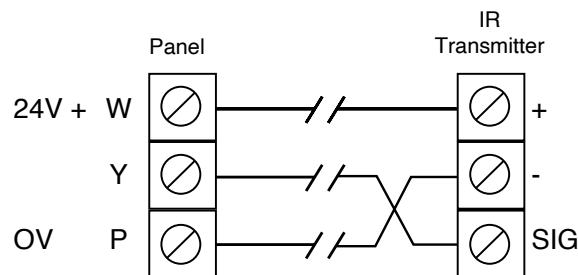

- RED ident (R) = flammable
- YELLOW ident (Y) = toxic
- BLUE ident (B) = oxygen
- GREEN ident (G) = others

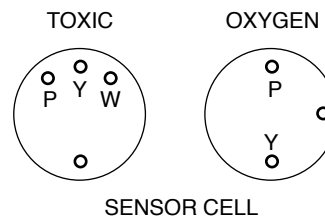

Fig. 6

CV TRANSMITTER

FLAMMABLE

Technical Sheet ref C323Fv2

TECHNICAL

Gas Type – Flammable Gases

Input Voltage – 12~30vDC – 24v nominal

Current – Nominal 160mA

Output Standard – Analogue 4~20mA (250 ohms max) – 3 wire (source mode – standard)

Option 1~5v output – Link – LK1

Sensor Cable – 3 core 1.5mm screened, maximum cable loop resistance 20ohms

Alarm Relay Relay contacts S.P.C.O. rated 1A/24vDC RL2 3A/230vAC RL1

Options (safe area board only)

Fire Alarm panel signalling – Remove LK1

Logic output – JP1 position L and end of line link JP2 – normally set at A (analogue)

Full Board Options – On board sounder

INSTALLATION

For hazardous area equipment see specific instructions supplied with the equipment, or visit our website for technical information. Siting of the equipment should be chosen with regard to the following points:

1. Away from sources of heat and with room for adequate air circulation.
2. Within easy reach for operating and maintenance personnel.
3. Connecting cables to be electrically shielded, i.e. M.I.C.C., steel wire armoured, screened cable or steel conduit.
4. For sensor location see our website.

NOTE: Sensor cables should not be run in the same ducting as power cables.

SET UP

1. Having powered up allow 5 minutes for the sensor to stabilise.
2. The sensor current/voltage should be set by connecting a voltmeter (mV range) across TP3/TP4 and adjusting the sensor voltage potentiometer (10 turn) until the required voltage reading is obtained (mV meter reading = mA sensor current) caution – do not exceed 360mV (mA). See sensor cell supply table.
3. Zero the card in clean air by adjustment of the potentiometer marked zero until the green ON/Zero LED just turns from GREEN/RED to GREEN. (At this point the output will = 4mA). If you require to check this, connect a digital meter (mV range) to the test pins marked TP1 and TP2, if adjustment is required adjust the 4mA potentiometer (4mV = 4mA).
4. Where a digital panel meter is fitted to the CV card the reading may be adjusted by the DPM Z potentiometer (zero).

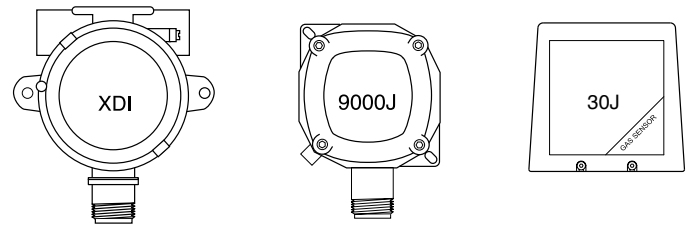

CALIBRATION

With the digital meter connected to the test pins TP1 and TP2 and a reading of (4mV clean air) apply test gas and wait until a maximum reading is obtained,

if necessary adjust the 20mA potentiometer for the required mV reading for the calibration gas being used.

Where 4 ~ 20mA span = 0 ~ 100% L.E.L. (Lower explosive level) and the sensor is to be calibrated for Methane which has an L.E.L. of 5% vol, when using 1% Methane in air test gas (20% L.E.L.) a reading of 7.2mv (7.2mA) would be required.

Where a Digital panel meter is fitted the display may be adjusted by using the DPM S potentiometer (span).

ADDITIONAL RELAY BOARD ALARM TRIP POINT ADJUSTMENT

This level will normally be set at 20% of the range reading i.e. 7.2mA.

1. Connect the DVM as above, using the zero potentiometer adjust for the required trip level (mv)
2. Adjust the alarm level potentiometer until the relay just changes state.
3. Using the zero potentiometer re-adjust the DVM to 4mV.

The above adjustment may be carried out in house by connecting the CV transmitter directly to a DC power supply.

SENSOR CELL SUPPLY TABLE

CAT300A	2v/300mA
CAT170A	2v/175mA
SEM-1	4v/170mA
WATCHGAS PRIME	4v/70mA
CAT335C	2.5v/335mA
THE300A	2v/300mA
SS10	2v/175mA
CAT335A	2.5v/335mA
CAT335B	2.5v/335mA
CAT100A	2v/100mA

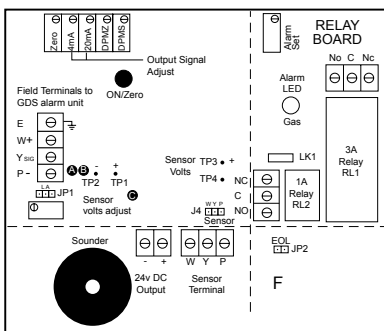

SAFE AREA SENSOR BOARD

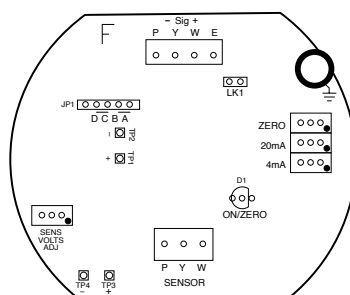

Exd SENSOR BOARD

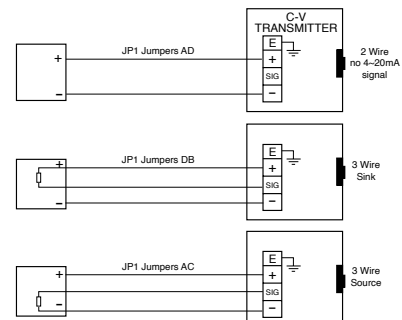

WATCHGAS 404+

Fig. 7

CV TRANSMITTER TOXIC/OXYGEN

Technical Sheet ref C323Fv2

TECHNICAL

Input Voltage – 12~30v DC – 24v nominal

Output Standard – Analogue 4~20 mA (250 ohms max) – source
Option 1~5v output – solder G

CV-Sensor Cable – 2 core screened

Alarm relay board options (safe area board only)

3 wire system only (2 wire if the 4~20mA signal is not used)

Signal relay contacts S.P.C.O. rated 1A/24v

Mains relay S.P.C.O. 3A/230v AC

Trip Indicator LED – trip point selectable 10% to full scale

Fire Alarm panel signalling – cut F

Logic output – JP3 position L and end of line link JP4

Full board (safe area board only)

On board sounder

Auxiliary output DC volts – standard—as input volts 24v

DPM – gas readout display – (zero and span potentiometers used only for DPM setting)

INSTALLATION

For hazardous area equipment see specific instructions supplied with the equipment, or visit our website for technical information. Siting of the equipment should be chosen with regard to the following points:

1. Away from sources of heat and with room for adequate air circulation.
2. Within easy reach for operating and maintenance personnel.
3. Connecting cables to be electrically shielded, i.e. M.I.C.C., steel wire armoured, screened cable or steel conduit.
4. For sensor location see our website.

NOTE: Sensor cables should not be run in the same ducting as power cables.

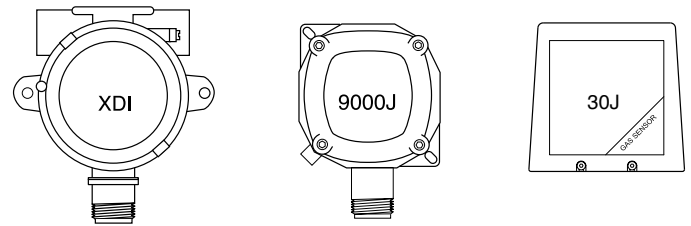

CALIBRATION

1. Connect a digital voltmeter (millivolt range) to the + and – test terminals (2 wire system) or X and Y test terminals (3 wire system). For 3 wire systems the CV is preset in the current source mode.
2. In clean air check that the DVM reads 4mV, if not adjust the 4mA potentiometer on the CV transmitter board.
3. Apply test gas and wait until a maximum DVM reading is obtained, if necessary adjust the 20mA potentiometer for the required mV reading for the calibration gas used (see range/reading on test certificate or printed on the CV circuit board).
4. For oxygen level monitoring remove the sensor terminal connector from the PCB J4 or yellow wire and adjust the 4mA potentiometer for 4mA (4mV).
5. Where a digital panel meter is fitted to the CV card the reading may be adjusted by the DPM Zero potentiometer.

Reconnect the cell and allow reading to stabilise adjust the DVM reading for 17.3mA (20.8% ambient oxygen) using the 20mA potentiometer. Where a Digital panel meter is fitted the display may be adjusted by using the DPM S potentiometer (span).

ADDITIONAL RELAY BOARD ALARM TRIP POINT ADJUSTMENT

This level will normally be set at 20% of the range reading i.e. 7.2mA.

1. Connect the DVM as above, using the 4mA potentiometer adjust for the required trip level.
2. Adjust the alarm level potentiometer until the alarm LED just comes on.
3. Using the 4mA potentiometer re-adjust the DVM to 4mV.

The above adjustment may be carried out in house by connecting the CV transmitter directly to a DC power supply.

Should a full board be required to operate on a 2 wire loop then the relay must be disabled – remove JP2

GAS TYPE PROGRAMMING – WORKS/PRESET

CO, H₂S, SO₂, NH₃, H₂ remove R4, R6, R10, R15, R28, R29,
HCN remove R4, R6, R8, R10, R15, R28, R29,
NO₂, CL₂ O₃, remove R4, R7, R10, R11, R28, R29
NO, HCL, C₂H₄O remove R3, R4, R6, R10, R12, R15, R28, R29,
O₂ remove R3, R8, R6, R15, R42, R43, IC-U2

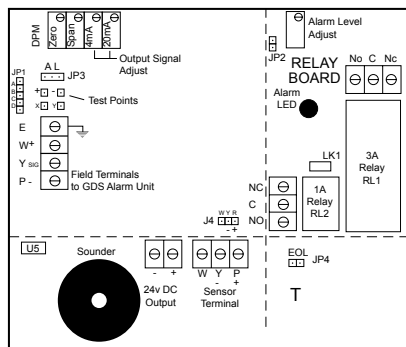

SAFE AREA BOARD

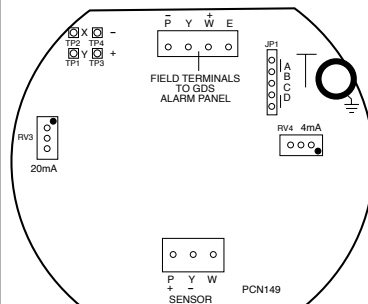

Exd BOARD

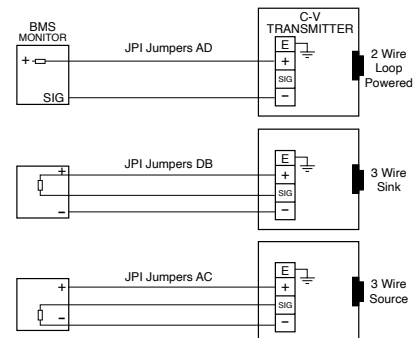

Fig. 8

XDI-XDIWIN – 15/30J

FLAMMABLE SENSOR – CATALYTIC PELLISTOR

General Data Sheet: 198D1C Issue S.v13
 Technical Sheet ref C893A

POWER SUPPLY

15 to 30Vdc 24v nominal

OUTPUTS

3 wire 4~20mA / 4 wire CANbus

Relays Low alarm SPCO
 High alarm SPCO 0–5A @ 30Vdc
 Fault alarm SPCO
 Inhibit option during servicing

Logging Intervals – variable time
 Roll over/stop
 Storage – 2,880 readings

Requires RS232 lead
 PC or laptop (dedicated)
 Hyperterminal (download from WatchGas website)

SET UP PROCEDURE:

New sensors are supplied ready to connect to the system. The following procedure is for full set up and where the sensor cell has been replaced – only sections 5, 6, 7, 9 and 11 need to be carried out.

Voltage measurements are made wrt AG unless otherwise specified.

1. Insert jumpers J20 and J6 position SO for 4–20mA source output.
2. Turn sensor voltage potentiometer anti-clockwise (minimum voltage).
3. Connect sensor to J2 terminal W–white Y–yellow P–pink.
4. Connect 24V + and 0V to JP10, short the 4–20mA terminal by inserting test link at J9.
5. Measure the sensor voltage at SV and adjust by turning sensor volts pot for the correct reading.

DO NOT EXCEED THE REQUIRED VOLTAGE OTHERWISE PERMANENT DAMAGE WILL OCCUR. See sensor cell supply table.

6. Rotate 20mA pot fully anti-clockwise (minimum span.)
7. When in clean air the sensor bridge is zeroed by adjusting zero pot until the dual colour LED D1 is off.
8. Connect PC hyper terminal using RS232 Combi adaptor (part no. 160–510 and lead part no. 160–515) at 4800 baud connected to J3. Ensure jumper J29 is fitted before programming and initialise the sensor using (C) calibration mode, then shift + (\$) command from the keyboard.
9. Using a digital mV meter measure across test pins TP8/9 and adjust 4mA pot for 4mA (zero) = 4mV
10. Then press (Z) on the PC to zero the reading.
11. Apply a known test gas to the sensor (56% LEL = 2.5% vol methane) for 1 minute at a flow rate of 1 litre to give a 13mA = 13mV across test pins TP8/9, adjust 20mA pot for correct mV reading.
12. When using a PC press (S) to enter span mode and using (H) or (L) adjust the reading to 56% LEL.
13. Press (space) to exit span and then (X) to exit the calibration mode.

An example of continuous data output to the PC from a Flammable sensor is shown below and is the format for all gas types. O, H and L represent the Over Range High and Low alarms respectively.

```
Flam %LEL
OHLDFI
^^v
-*--*-Gas val = 35.6
```

D indicates if a duplicate address is detected

F indicates a fault present

I shows that this sensor has its alarms inhibited under the O H L the ^^v represent the direction of the alarms. L is falling and H and O are rising. A(*) under the letter(s) OHLDFI represents a detected state so in this example the sensor would be in high alarm and a fault present.

'Gas val 35.6' represents the value of the gas present at the sensor head. Pressing (R) on the PC causes a reset to occur. Gas type with address and serial number are then output to the PC together with alarms and calibration date.

A full command list via PC is available by pressing the letter (P) which will relist on the PC.

COMMAND	USE
A = Set CAN address	Sets the CAN address
G = Select gas type	Select the gas type from a list
Z = Zero	Press when no gas on sensor to give zero
S = Span	Use when calibration gas applied, H and L change reading
D = Enter calibration date	Enter the calibration date
Y = Toggle auto zero	Auto zero is ON or OFF, small drift is cleared
H = Set high alarm	Sets the high alarm threshold
L = Set low alarm	Sets the low alarm threshold
O = Set over range alarm	Sets the over range alarm threshold
P = List command	List these commands on screen
X = Exit calibration mode	Exit this PC mode
\$ = Initialise this sensor	Use on new PCB to set gas type to Flam
U = Alarm direction	Sets rising or falling alarms
R = Range	Allows a change in maximum value
N = Decimal points	Toggles between 1 and 2 decimal places
E = Edit user gas text	Choose gas description
B = Toggle deadband	Deadband of 2.5% can be on or off
F = Toggle fault Input	External fault input contact can be disabled
# = Normally energised	Low /high alarm relays and fault relay can be made normally energised
V = View gas log	From current log, display how many historical readings to display, up to 2880
% = Clear gas log	Set all 2880 log readings to 0.00
I = Log interval log	Choose how many seconds between each reading and whether the log will roll over or stop at 2880 (60 second interval and 2880 readings = 48 hours)

14. Connect the sensor to a Combi alarm panel and ensure that it reports in correctly. **NOTE:** Fit the end of line (EOL) link J1 if the sensor is to be installed at the end of the sensor cable.
15. If front panel display board is fitted via connector J5 and U12 adjust contrast for LCD contrast.
16. Remove J9 test link for normal operation.
17. Insert link J12 to enable the bridge fault detection. (4–20mA output falls to 2mA in fault).
18. Ensure J29 address link is removed (this is only used when changing address from a Panel).

XDI-XDIWIN – 15/30J

FLAMMABLE SENSOR – CATALYTIC PELLISTOR

General Data Sheet: 198D1C Issue S.v13
 Technical Sheet ref C893A

USING MAGNETS (SET UP)

The Combi sensors which have an LCD display fitted also incorporate 3 reed switches which can be activated using external magnets through the glass window of the flameproof XDiwin enclosure. **These magnets do not act instantly and have to be in close proximity to L, M and R on the front display for a few seconds to activate a software setup function.**

The left magnet enters the Auto zero ON or OFF menu. This allows small drift changes in the sensor to be compensated for but is not operational when the sensor readings are greater than 5% of full scale. Therefore auto zero is inactive when a larger gas reading is present. When the remove magnets message appears, move the left magnet away and then the display shows if auto zero is ON or OFF. The left magnet puts auto zero ON and the right magnet turns it OFF. With no magnets present, the display will return to normal after a few seconds timeout.

The right magnet allows the CAN address of the sensor to be changed. When the ADDRESS menu is displayed with a prompt to remove the magnet, and then the display shows the address and that the right magnet decreases it whilst the left magnet will increase it. This is then stored in internal non volatile memory and the display will automatically revert to normal operation.

The centre magnet is used to inhibit the sensor. As with the left and right magnet functions the display requests that you remove the magnet and then the state of the inhibit appears on the LCD. The left magnet then puts the sensor into inhibit whilst the right magnet removes it. An amber LED on the front panel under the LCD flashes when the sensor is inhibited. When all magnets are removed, the display will revert to normal operation.

The left and right magnets together allow the calibration menu to be used.

Removing both magnets as instructed on the LCD presents the first part of this multi menu which is ZERO. With no gas present use the left magnet to increase the reading and the right magnet to decrease to achieve a zero reading on the display. A timer is displayed on the LCD and when this reaches 0, the next menu is displayed. This timer is 15 seconds approximately and is reset back each time a magnet is near. Waiting till timeout is acceptable but this timeout can be speeded up by placing a magnet near to the centre position.

SPAN is the next part of the menu and gas should be applied to the sensor at this time.

The left magnet increases the gain and the right magnet reduces gain. The actual sensor value can be seen on the display to rise or fall respectively.

LOW ALARM is the next menu and left and right magnets increase and decrease this value.

HIGH ALARM is next followed by OVER RANGE alarm.

The direction of the alarms is displayed as ^ for rising and v for falling but these can be changed using left and right magnets together.

SENSOR CELL SUPPLY TABLE

CAT300A	2v/300mA
CAT170A	2v/175mA
SEM-1	4v/170mA
WATCHGAS PRIME	4v/70mA
CAT335C	2.5v/335mA
THE300A	2v/300mA
SS10	2v/175mA
CAT335A	2.5v/335mA
CAT335B	2.5v/335mA
CAT100A	2v/100mA

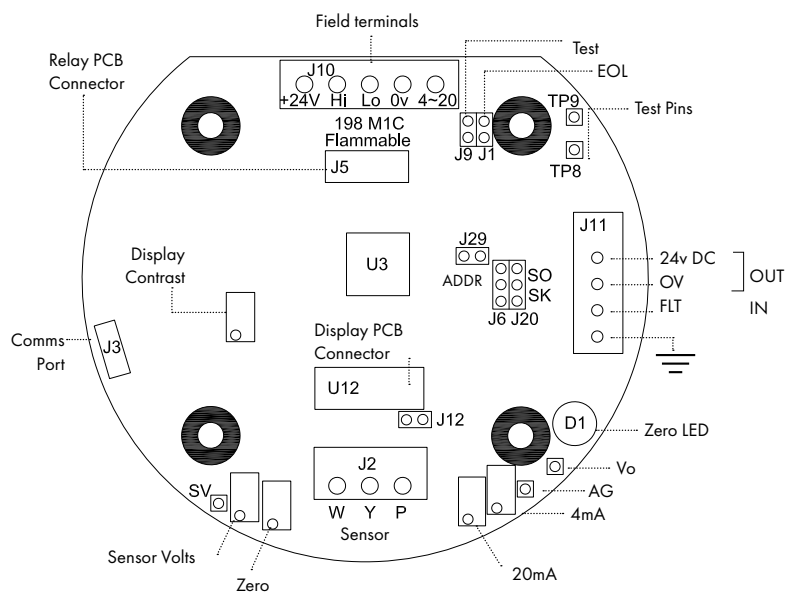

Fig.1

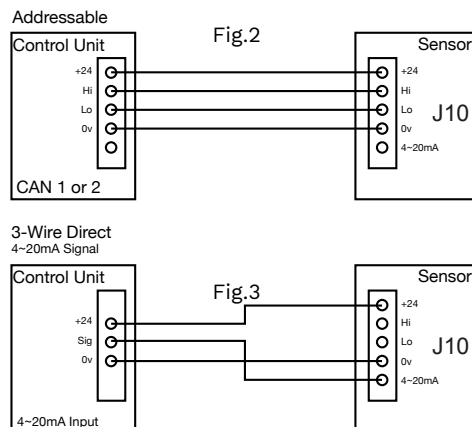

Fig.9

XDI-XDIWIN – 15/30J

TOXIC / OXYGEN SENSOR

General Data Sheet: 204D1C Issue Tv4
 Technical Sheet ref C894

POWER SUPPLY

15 to 30Vdc 24v nominal

OUTPUTS

2 wire 4~20mA output only
 3 wire 4~20mA output +
 4 wire CANbus

Relays	Low alarm	SPCO
	High alarm	SPCO 0–5A @ 30Vdc
	Fault alarm	SPCO
	Inhibit option during servicing	
Logging	Intervals – variable time	
	Roll over/stop	
	Storage – 2,880 readings	
Requires	RS232 lead	
	PC or laptop (dedicated)	
	Hyperterminal (download from WatchGas website)	

SET UP PROCEDURE:

Direct 4~20mA 2/3 wire (no processor)

New sensors are supplied ready to connect to a system with all jumpers inserted. This procedure shows how to recalibrate as part of routine maintenance or cell replacement.

The first part is to set up the 4~20mA section which is produced by the CELL circuit. Note some cells take time to stabilise. If used as 2 or 3 wire then only steps 1 to 5 are required.

1. Connect the cell to terminal J2 and use +24V, 0V and 4~20mA connections on terminal J10 for 3 wire (or +24V and 4~20mA for 2 wire – see note)
2. Measure voltage across test pins AG to Vo and adjust reading to zero mV using offset potentiometer
3. Measure the output current mV=mA at test pins TP1/TP2 and adjust reading to 4mV using 4mA pot
4. Apply span gas to cell and adjust 20mA pot to give correct mV reading at test pins TP1/TP2. NOTE: at 50% span gas, the mV reading at TP1/TP2 should be 12mV and the voltage across test pins AG and Vo should not exceed 1 volt so that 100% of range is achievable.
5. Remove the span gas and re-adjust 4mA pot to 4mV if re-

quired. **4 wire CANbus / 3 wire 4~20mA with processor communication**

6. With power applied ensure that MPU led is flashing and the CAN led is on or flashing.
7. Connect RS232 pod to J3 connector and to a PC running HyperTerminal at 4800 baud. Ensure jumper J29 is fitted before programming.
8. The terminal output screen shows continuous data output/commands and allows input from the PC keyboard. Pressing 'C' enters calibration mode
 - a. Press 'SHIFT \$' to initialise the sensor and reset to default "Flam 100% LEL" setting.
 - b. Then press 'G' to change the gas type to match the cell being used.
 - c. **NOTE:** the range of the new gas has a default value but can be changed by pressing 'R'.
 - d. Press 'A' to change the address of this sensor if required
 - e. Press 'N' to select the number of decimal places to 1 or 2, (ie: dp=1 or dp=2)
 - f. With no gas applied and 4mV measured at test pins TP8/TP9 press 'Z' to zero the gas reading/see note.
 - g. Then apply span gas and press 'S' to enter span mode, obtain correct mV reading for test gas used by adjusting 20mA pot. The displayed reading can be made HIGHER by pressing 'H' or lower by pressing 'L'
 - h. Pressing 'SPACE BAR' will exit the span mode
 - i. Press 'V' to view log of sensor readings if required
 - j. Pressing 'X' will exit the calibration mode.

NOTE: Oxygen cells only use the P+ and Y terminals J2. To adjust for "zero" it is normal practice to disconnect 1 wire from the cell and adjust the 4mA pot for a 4mV reading across test pins TP8/TP9 FOR 3 wire sensors, or for 2 wire sensors use TP1/TP2. When the cell is reconnected in air at 20.8% oxygen the span can be adjusted for 17.3mV reading across the same test pins using 20mA pot.

If an LCD option is fitted then calibration and other settings using magnets instead of a PC can be achieved – see over.

COMMAND	USE
A = Set CAN address	Sets the CAN address
G = Select gas type	Select the gas type from a list
Z = Zero	Press when no gas on sensor to give zero
S = Span	Use when calibration gas applied, H and L change reading
D = Enter calibration date	Enter the calibration date
Y = Toggle auto zero	Auto zero is ON or OFF, small drift is cleared
H = Set high alarm	Sets the high alarm threshold
L = Set low alarm	Sets the low alarm threshold
O = Set over range alarm	Sets the over range alarm threshold
P = List command	List these commands on screen
X = Exit calibration mode	Exit this PC mode
\$ = Initialise this sensor	Use on new PCB to set gas type to Flam

COMMAND	USE
U = Alarm direction	Sets rising or falling alarms
R = Range	Allows a change in maximum value
N = Decimal points	Toggles between 1 and 2 decimal places
E = Edit user gas text	Choose gas description
B = Toggle deadband	Deadband of 2.5% can be on or off
F = Toggle fault Input	External fault input contact can be disabled
# = Normally energised	Low / high alarm relays and fault relay can be made normally energised
V = View gas log	From current log, display how many historical readings to display, up to 2880
% = Clear gas log	Set all 2880 log readings to 0.00
I = Log interval	Choose how many seconds between each reading and whether the log will roll over or stop at 2880 (60 second interval and 2880 readings = 48 hours)

XDI-XDIWIN – 15/30J TOXIC / OXYGEN SENSOR

General Data Sheet: 204D1C Issue Tv4
Technical Sheet ref C894

USING MAGNETS (SET UP)

The Combi sensors which have an LCD display fitted also incorporate 3 reed switches which can be activated using external magnets through the glass window of the flameproof XDIwin enclosure. **These magnets do not act instantly and have to be in close proximity to L, M and R on the front display for a few seconds to activate a software setup function.**

The left magnet enters the Auto zero ON or OFF menu.

This allows small drift changes in the sensor to be compensated for but is not operational when the sensor readings are greater than 5% of full scale. Therefore auto zero is inactive when a larger gas reading is present. When the remove magnets message appears, move the left magnet away and then the display shows if auto zero is ON or OFF. The left magnet puts auto zero on and the right magnet turns it off. With no magnets present, the display will return to normal after a few seconds timeout.

The right magnet allows the CAN address of the sensor to be changed. WHEN the ADDRESS menu is displayed with a prompt to remove the magnet, and then the display shows the address and that the right magnet will decrease it whilst the left magnet will increase it. This is then stored in internal non volatile memory and the display will automatically revert to normal operation.

The centre magnet is used to inhibit the sensor. As with the left and right magnet functions the display requests that you remove the magnet and then the state of the inhibit appears on the LCD. The left magnet then puts the sensor into inhibit whilst the right magnet removes it. An amber LED on the front panel under the LCD flashes when the sensor is inhibited. When all magnets are removed, the display will revert to normal operation

The left and right magnets together allow the calibration menu to be used.

Removing both magnets as instructed on the LCD presents the first part of this multi menu which is ZERO. With no gas present use the left magnet to increase the reading and the right magnet to decrease to achieve a zero reading on the display. A timer is displayed on the LCD and when this reaches 0, the next menu is displayed. This timer is 15 seconds approximately and is reset back each time a magnet is near. Waiting till timeout is acceptable but this timeout can be speeded up by placing a magnet near to the centre position.

SPAN is the next part of the menu and gas should be applied to the sensor at this time.

The left magnet increases the gain and the right magnet reduces gain. The actual sensor value can be seen on the display to rise or fall respectively.

LOW ALARM is the next menu and left and right magnets increase and decrease this value.

HIGH ALARM is next followed by OVER RANGE alarm.

The direction of the alarms is displayed as ^ for rising and v for falling but these can be changed using left and right magnets together.

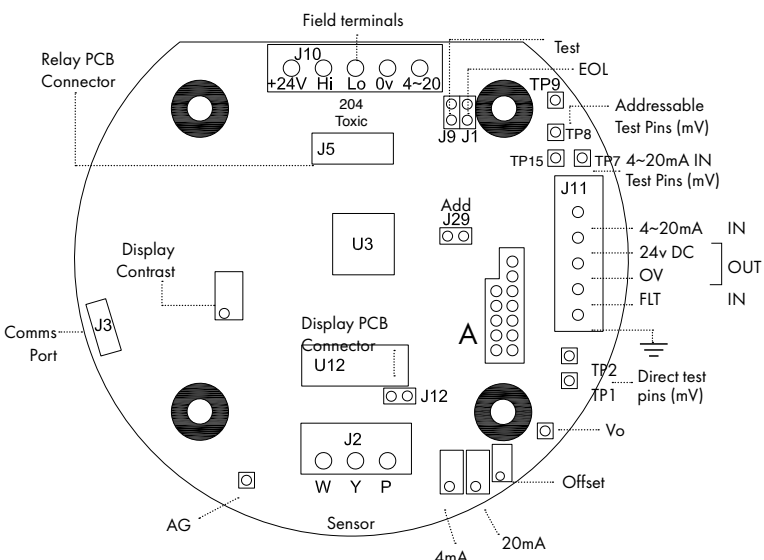

Fig.1

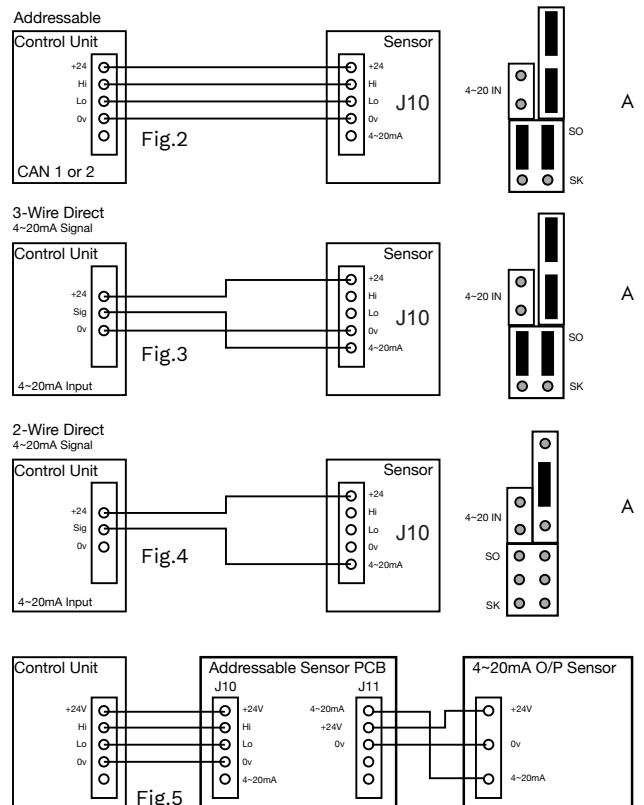

Fig. 10

XDI-XDIWIN – 15/30J

PRIME SENSOR

Technical Sheet ref C1698 Issue Bv.4

POWER SUPPLY

15 to 30Vdc 24v nominal

OUTPUTS

3 wire 4~20mA / 4 wire CANbus

Relays Low alarm SPCO
(when High alarm SPCO 0–5A @ 30Vdc
fitted) Fault alarm SPCO

Inhibit option during servicing

Logging Intervals – variable time

Roll over/stop

Storage – 2,880 readings

Requires RS232 lead

PC or laptop (dedicated)

Hyperterminal (download from WatchGas website)

SET UP PROCEDURE:

New sensors are supplied ready to connect to the system. The following procedure is for full set up and where the sensor cell has been replaced – only sections 5, 6, 7, 9 and 11 need to be carried out. Voltage measurements are made wrt AG unless otherwise specified.

1. Insert jumpers J20 and J6 position SO for 4–20mA source output.
2. Turn sensor voltage potentiometer anti-clockwise (minimum voltage).
3. Connect sensor to J2 terminal W–white Y–yellow P–pink.
4. Connect 24V + and 0V to JP10, short the 4~20mA terminal by inserting test link at J9.
5. Measure the sensor voltage at SV and adjust by turning sensor volts pot for the correct reading 4Vdc. **DO NOT EXCEED THE REQUIRED VOLTAGE OTHERWISE PERMANENT DAMAGE WILL OCCUR.**
6. Rotate 20mA pot fully anti-clockwise (minimum span).
7. When in clean air the sensor bridge is zeroed by adjusting zero pot until the dual colour LED D1 is off.
8. Connect PC hyper terminal using RS232 Combi adaptor (part no. 160–510 and lead part no. 160–515) at 4800 baud connected to J3 and initialise the sensor using (C) calibration mode, then shift + (\$) command from the keyboard.
9. Using a digital mV meter measure across test pins TP8/9 and adjust 4mA pot for 4mA (zero) = 4mV
10. Then press (Z) on the PC to zero the reading.
11. Apply a known test gas to the sensor (50% F.S.D.) for 1 minute at a flow rate of 1 litre to give a 12mA = 12mV across test pins TP8/9, adjust 20mA pot for correct mV reading.
12. When using a PC press (S) to enter span mode and using (H) or (L) adjust for the correct reading.
13. Press (space) to exit span and then (X) to exit the calibration mode.

An example of continuous data output to the PC from a Flammable sensor is shown below and is the format for all gas types. O, H and L represent the Over Range High and Low alarms respectively.

```
Flam %LEL
OHLDFI
^^v
-*--*-Gas val = 35.6
```

D indicates if a duplicate address is detected

F indicates a fault present

I shows that this sensor has its alarms inhibited under the O H L the ^^v represent the direction of the alarms. L is falling and H and O are rising. A(*) under the letter(s) OHLDFI represents a detected state so in this example the sensor would be in high alarm and a fault present.

'Gas val 35.6' represents the value of the gas present at the sensor head. Pressing (R) on the PC causes a reset to occur. Gas type with address and serial number are then output to the PC together with alarms and calibration date.

A full command list via PC is available by pressing the letter (P) which will relist on the PC.

COMMAND	USE
A = Set CAN address	Sets the CAN address
G = Select gas type	Select the gas type from a list
Z = Zero	Press when no gas on sensor to give zero
S = Span	Use when calibration gas applied, H and L change reading
D = Enter calibration date	Enter the calibration date
Y = Toggle auto zero	Auto zero is ON or OFF, small drift is cleared
H = Set high alarm	Sets the high alarm threshold
L = Set low alarm	Sets the low alarm threshold
O = Set over range alarm	Sets the over range alarm threshold
P = List command	List these commands on screen
X = Exit calibration mode	Exit this PC mode
\$ = Initialise this sensor	Use on new PCB to set gas type to Flam
U = Alarm direction	Sets rising or falling alarms
R = Range	Allows a change in maximum value
N = Decimal points	Toggles between 1 and 2 decimal places
E = Edit user gas text	Choose gas description
B = Toggle deadband	Deadband of 2.5% can be on or off
F = Toggle fault Input	External fault input contact can be disabled
# = Normally energised	Low /high alarm relays and fault relay can be made normally energised
V = View gas log	From current log, display how many historical readings to display, up to 2880
% = Clear gas log	Set all 2880 log readings to 0.00
I = Log interval	Choose how many seconds between each reading and whether the log will roll over or stop at 2880 (60 second interval and 2880 readings = 48 hours)

14. Connect the sensor to a Combi alarm panel and ensure that it reports in correctly. **NOTE:** Fit the end of line (EOL) link J1 if the sensor is to be installed at the end of the sensor cable.
15. If front panel display board is fitted via connector J5 and U12 adjust contrast for LCD contrast.
16. Remove J9 test link for normal operation.
17. Insert link J12 to enable the bridge fault detection. (4–20mA output falls to 2mA in fault).
18. Ensure J29 address link is removed (this is only used when changing address from a Panel).

XDI-XDIWIN – 15/30J PRIME SENSOR

Technical Sheet ref C1698 Issue Bv.4

USING MAGNETS (SET UP)

The Combi sensors which have an LCD display fitted also incorporate 3 reed switches which can be activated using external magnets through the glass window of the flameproof XDIwin enclosure. **These magnets do not act instantly and have to be in close proximity to L, M and R on the front display for a few seconds to activate a software setup function.**

The left magnet enters the Auto zero ON or OFF menu. This allows small drift changes in the sensor to be compensated for but is not operational when the sensor readings are greater than 5% of full scale. Therefore auto zero is inactive when a larger gas reading is present. When the remove magnets message appears, move the left magnet away and then the display shows if auto zero is ON or OFF. The left magnet puts auto zero ON and the right magnet turns it OFF. With no magnets present, the display will return to normal after a few seconds timeout.

The right magnet allows the CAN address of the sensor to be changed. When the ADDRESS menu is displayed with a prompt to remove the magnet, and then the display shows the address and that the right magnet decreases it whilst the left magnet will increase it. This is then stored in internal non volatile memory and the display will automatically revert to normal operation.

The centre magnet is used to inhibit the sensor. As with the left and right magnet functions the display requests that you remove the magnet and then the state of the inhibit appears on the LCD. The left magnet then puts the sensor into inhibit whilst the right magnet removes it. An amber LED on the front panel under the LCD flashes when the sensor is inhibited. When all magnets are removed, the display will revert to normal operation.

The left and right magnets together allow the calibration menu to be used.

Removing both magnets as instructed on the LCD presents the first part of this multi menu which is ZERO. With no gas present use the left magnet to increase the reading and the right magnet to decrease to achieve a zero reading on the display. A timer is displayed on the LCD and when this reaches 0, the next menu is displayed. This timer is 15 seconds approximately and is reset back each time a magnet is near. Waiting till timeout is acceptable but this timeout can be speeded up by placing a magnet near to the centre position.

SPAN is the next part of the menu and gas should be applied to the sensor at this time. The left magnet increases the gain and the right magnet reduces gain. The actual sensor value can be seen on the display to rise or fall respectively.

LOW ALARM is the next menu and left and right magnets increase and decrease this value.

HIGH ALARM is next followed by OVER RANGE alarm.

The direction of the alarms is displayed as ^ for rising and v for falling but these can be changed using left and right magnets together.

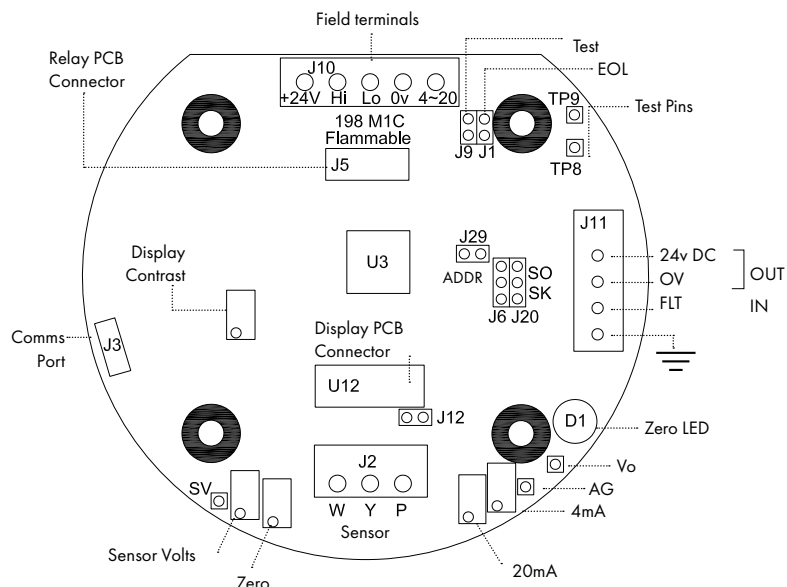

Fig.1

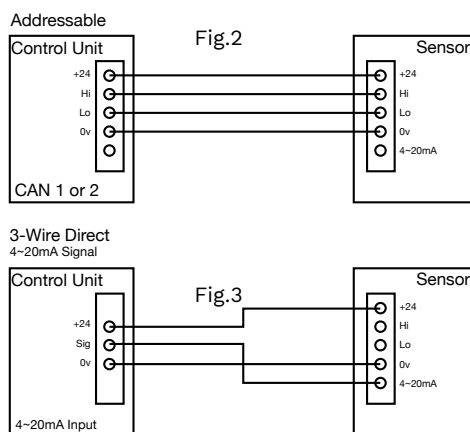

Fig. 11

XDI-XDIWIN – 15/30J

4~20MA INPUT

Set up procedure: 204D2C Issue Tv3
 Technical Sheet ref C1180

NEW UNITS ARE SUPPLIED READY TO CONNECT TO A SYSTEM. THE FOLLOWING PROCEDURE MAY NEED TO BE CARRIED OUT FOLLOWING CHANGES TO THE SYSTEM:

1. Insert J8 jumper to receive signal from external 4~20mA source (Fig.3)
2. Connect external 4~20mA source to the 4~20mA input terminal (J11) on the right hand side of the board.
3. Connect terminal J10 as shown in Fig.2
4. Connect DVM (mV range) across TP7 + TP15 to measure current supplied by 4~20mA device (mV = mA)
5. Ensure that the CAN LED is ON and flashing occasionally.
6. Connect RS232 pod to connector J3 and to a PC running HyperTerminal at 4800 baud.
7. The HyperTerminal display shows a continuous data output and allows input from the PC keyboard.
 - a. Press C to enter calibration mode
 - b. Press shift \$ to initialise the memory if new PCB (defaults to Flam %LEL)
 - c. Press G to change gas/signal to the type required for the cell/unit in use. (NOTE: When using a 'user gas' press 'E' to edit name after using 'G' to select. Also make sure to select a vacant user gas number, 61-68, as the addressable sensor will overwrite data entered at the Combi panel.
 - d. The range of the gas/signal selected will have a default setting which can be changed by pressing 'R'
 - e. Press A and enter CAN address of this sensor
 - f. Press N to toggle the number of decimal places between 1 and 2 (i.e. dp=1 or dp=2)
 - g. Press B to toggle the deadband ON and OFF
 - h. Press F to toggle the external fault option ON or OFF (only available when external source has local fault indication)
 - i. With input signal reading 4mA press Z to zero the reading.
 - j. Press S to span the reading. Apply gas / signal from external source and press H or L to adjust the reading.
 - k. Press space to exit the span.
 - l. Press X to exit the calibration mode.
8. Connect to a combi panel and ensure that the sensor reports in correctly.
9. **Note:** that if this sensor is at the end of the communication wires then it will need terminating by inserting jumper J1(E-OL). The continuous data output when connected to HyperTerminal is the same format as for the Flammable sensor. The software used is identical.

COMMAND	USE
A = Set CAN address	Sets the CAN address
G = Select gas type	Select the gas type from a list
Z = Zero	Press when no gas on sensor to give zero
S = Span	Use when calibration gas applied, H and L change reading
D = Enter calibration date	Enter the calibration date
Y = Toggle auto zero	Auto zero is ON or OFF, small drift is cleared
H = Set high alarm	Sets the high alarm threshold
L = Set low alarm	Sets the low alarm threshold
O = Set over range alarm	Sets the over range alarm threshold
P = List command	List these commands on screen
X = Exit calibration mode	Exit this PC mode
\$ = Initialise this sensor	Use on new PCB to set gas type to Flam
U = Alarm direction	Sets rising or falling alarms
R = Range	Allows a change in maximum value
N = Decimal points	Toggles between 1 and 2 decimal places
E = Edit user gas text	Choose gas description
B = Toggle deadband	Deadband of 2.5% can be on or off
F = Toggle fault Input	External fault input contact can be disabled
# = Normally energised	Low /high alarm relays and fault relay can be made normally energised
V = View gas log	From current log, display how many historical readings to display, up to 2880
% = Clear gas log	Set all 2880 log readings to 0.00
I = Log interval	Choose how many seconds between each reading and whether the log will roll over or stop at 2880 (60 second interval and 2880 readings = 48 hours)

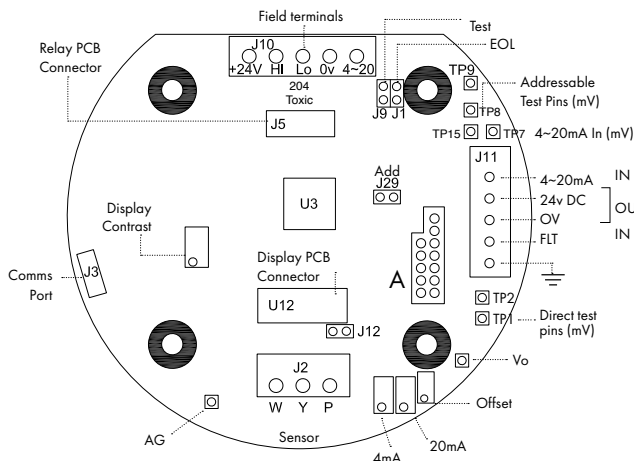

Fig.1

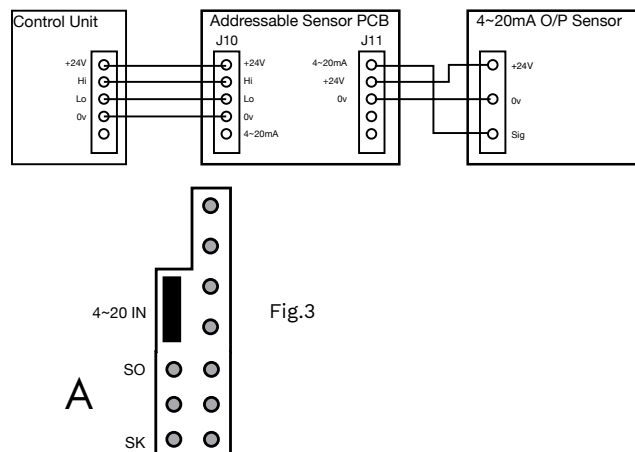

Fig.3